



# biolinguistics

volume 6, issue 1

winter 2012

XP

XP

...

$\gamma$

$\alpha$

...

XP

ISSN 1450-3417



# Solving the UG Problem

Denis Bouchard

Many generalizations are impossible to learn via primary linguistic data, so they are assumed to be part of our genetic endowment. Generativists have tried to reduce Universal Grammar (UG) to a minimum, in particular by appealing to computational efficiency. In principle, this is an important improvement. The bottom line, however, is how well this computational approach explains the data. Unfortunately, it does not. Thus current analyses of subject–AUX inversion still appeal implicitly to several UG constraints in addition to structure dependence. Moreover, this fails empirically even in the wildest cases, such as forming questions by reversing the word order of a declarative. Fortunately, there is a way out of this impasse. Learners realize that different orders of constituents correlate with different meanings. Generating Tense in Comp compositionally derives a polar interrogative interpretation. The logically prior properties of the perceptual and conceptual systems impose constraints that are sufficient to explain language acquisition.

*Keywords:* learnability; semantics; structure dependence; Universal Grammar

## 1. The Problem with Universal Grammar

Language is a bidirectional link between sound and meaning. To explain how this system works, a first step is to describe as much of the facts as possible. The earliest efforts to address this problem typically involve a rich descriptive apparatus, which is gradually simplified by uncovering generalizations and explaining some of the facts by principles and laws recruited from other domains with which language interacts. The properties of the language that learners attain are determined by three factors (Chomsky 2005): Genetic endowment (the topic of Universal Grammar), personal experience, and principles that are language- or even organism-independent.

Some facts are particularly problematic for the descriptive apparatus. Chomsky replaced the question of what takes place in languages by the question of what takes place in speakers. In this biolinguistic perspective, the problem of acquisition becomes crucial: Once we have proposed a model of linguistic

---

I am grateful to two anonymous reviewers for comments that helped me present some points more clearly.



competence, we have to provide a convincing scenario about the way children come to master a system as complex as language so quickly and uniformly. For some 50 years in the generative framework, the answer was assumed to be in Universal Grammar (UG).<sup>1</sup> Many of the generalizations expressed by generative principles seem to be impossible to learn on the basis of primary linguistic data because it would require negative data. So children seem to know more about language than what they could learn from their experience. This is the argument of poverty of stimulus (POS). Generativists conclude that UG restricts the acquisition path. Children do not have to learn these principles since they are part of their genetic endowment, and they cannot err outside of the path traced by these principles: They only choose among the options provided by UG those which conform with their experience.<sup>2</sup>

However, this enrichment of UG creates a tension with the explanatory value of the model. UG contains the unexplained elements of  $S_0$ : “UG is the residue when third factor effects are abstracted. The richer the residue, the harder it will be to account for the evolution of UG, evidently” (Chomsky 2007a: 19).<sup>3</sup> In contrast, operations and principles recruited by the faculty of language from other cognitive domains have a greater explanatory potential. Therefore:

A primary goal of linguistic theory since has been to try to reduce UG assumptions to a minimum, both for standard reasons of seeking deeper explanations, and also in the hope that a serious approach to language evolution, that is, evolution of UG, might someday be possible. There have been two approaches to this problem: one seeks to reduce or totally eliminate UG by reliance on other cognitive processes. (Chomsky 2011: 263)

Adherents to this approach often base their explanations on the communication function of language and the social context of normal use of expressions. Many rely on the statistical analysis of massive collections of utterances. They often

---

<sup>1</sup> See, for instance, Chomsky (1973: 232): “[T]he fundamental empirical problem of linguistics is to explain how a person can acquire knowledge of language [...]. To approach the fundamental empirical problem, we attempt to restrict the class of potential languages by setting various conditions on the form and function of grammars; the term ‘universal grammar’ has commonly been used to refer to the system of general constraints of this sort”.

<sup>2</sup> For a comprehensive presentation of the argumentation that UG constraints canalize acquisition, see Crain (1991). Crain & Pietroski (2006: 64) still adhere to the view that a UG component plays a prominent role in language acquisition: “[H]uman languages are transformational, and subject to constraints that (at least apparently) do not reflect basic principles of logic or communication or learnability [...]. The findings [...] reveal young children’s staunch adherence to the universal and unifying principles discovered by linguists working in the generative enterprise”.

<sup>3</sup> Chomsky (2010a) mentions his attempts to generalize rules and constraints as examples of this goal (see also Boeckx & Hornstein 2009). But generalizations do not imply that the rules or constraints should be dispensed with, only that their essence is better captured in these broader forms. Moreover, a minimal descriptive apparatus does not necessarily reduce the explanatory burden: A single highly implausible element on evolutionary grounds can raise severe problems of explanation. Also, we must evaluate the system as a whole, to insure that the generalization really reduces apparently different phenomena to the same operation, and does not require that we state the distinctions elsewhere in the system. For instance, the Move ‘generalization’ necessitates countless uninterpretable features that are construction (and even utterance) specific, so this system may be *less* general overall than a standard phrase structure system.

attempt to account for linear sequences of words and neglect properties such as ambiguities and non ambiguities due to the hierarchical organization of sentences. Chomsky has a harsh evaluation of this approach: “It has achieved almost no results, though a weaker variant — the study of interactions between UG principles and statistical-based learning-theoretical approaches — has some achievements to its credit” (Chomsky 2011: 263). A similar judgment holds for alternatives that propose to account for the acquisition of instances of POS by claiming that the learning capacity is better than asserted, or that the available data is richer (Berwick *et al.* 2011, Chomsky 2011).

The second approach to the UG problem is to try to reduce it by invoking more general principles. Chomsky assumes that these language-independent principles fall into two categories. First, there are interface conditions that the expressions generated by a language must satisfy because they are imposed on language by the systems with which it interacts. Second, assuming that language is a computational system, it is subject to ‘natural laws’ of computation, such as principles of efficient computation.

We can regard an explanation of properties of language as *principled* insofar as it can be reduced to properties of the interface systems and general considerations of computational efficiency and the like. (Chomsky 2005: 10)

He underlines the fact that these language-independent principles derive from a very general initial condition whose importance has been recognized since the origins of evolutionary biology: Natural selection necessarily operates within the options of form and development allowed by the laws of nature. “A very strong proposal, called ‘the strong minimalist thesis’, is that all phenomena of language have a principled account in this sense, that language is a perfect solution to interface conditions, the conditions it must satisfy to some extent if it is to be usable at all” (Chomsky 2007a: 20). In principle, this is an important improvement over a theory based on a UG store of constraints since it crucially relies on externally motivated properties, as argued extensively in Bouchard (2002).

In generative grammar, the emphasis is on computational tools: Interface conditions play a rather secondary role and function as external filters that the computations must satisfy. Consequently, the computational system for human language ( $C_{HL}$ ) is the main explanatory tool and little appeal is made to precise interface properties to explain precise linguistic properties. Very telling in this regard is the fact that when Chomsky (2005: 10) discusses these two types of language-independent principles, he provides several references to papers on efficient computation, but not one to studies on interface systems. The key explanatory concept is computational efficiency.

The bottom line however is how well this computational approach explains the data. Unfortunately, it does not fare well: it ends up requiring much more UG enrichment than is explicitly recognized, and it is also empirically inadequate because the system as a whole does not capture the facts about the acquisition of language. A clear illustration of this state of affairs can be found in the discussion of a stellar case of Poverty of the Stimulus — structure dependence. Despite 50 years of revisions of the initial characterization, the posited UG is not better

grounded, it requires the addition of several auxiliary hypotheses, and even then it does not actually handle the original examples, or the extended set of examples, and fails empirically even in the wildest cases. So in effect, it has achieved almost no results. Fortunately, there is a way out of this impasse. But first, let's see the nature of the problem.

## 2. Structure Dependence and UG

The formal precision of generative grammar has helped uncover many properties, but as I will now show, the engineering model actually gets in the way of figuring out what is going on, and why things are as they are. A good example is the decades of discussions surrounding what takes place in polar interrogatives like (1b).

- (1) a. The man is happy.  
b. Is the man \_\_ happy?

This kind of construction raises a key question: Why does the tensed verb appear in a particular position? From the earliest studies (Chomsky 1968, 1971: 25–28), this subject–AUX inversion has been used to argue that rules are structure dependent, and it is still discussed regularly today in essentially the same form as over four decades ago (Crain 1991, Pinker 1994, Bolender *et al.* 2008, Berwick & Chomsky 2008, Chomsky 2010a, 2010b, 2011, and Berwick *et al.* 2011, among many more). Structure dependence is important in generative argumentation for reasons that go far beyond the desire to find the precise description of question formation. The significance of this constraint lies in the assumption that it is innate, a language-specific property, because “the sample data for selecting a correct target hypothesis does not seem rich enough without positing *a priori* the principle in question” (Berwick & Chomsky 2008).

Chomsky has repeatedly argued that the corpora children have access to are unlikely to contain evidence that syntactic transformations are dependent on constituent structure, not on linear structure. For instance, Berwick & Chomsky (2008: 383) ask us to consider learners exposed to the pair of sentences in (1).

We then ask how a child might [...] choose between two competing rules for question formation, each rule operating via the ‘displacement’ of the auxiliary verb *is* to the front of the representation: rule (A), which is not structure-dependent but refers only to words and ignores phrase structure; and rule (B), which is structure-dependent and refers to phrase structure [...].

- (A) Front the first occurrence of *is*.  
(B) Front the structurally most prominent occurrence of *is*.

[...] Application of (A) leads to the correct result when applied to examples such as [(1)], but does not generalize correctly to [(2)], whereas (B) works properly on [(2)]. Children and adult grammars select (B), indicating that structure dependence is part of the *a priori* schematism.

- (2) a. The man who is tall is happy.  
 b. Is the man who is tall \_\_ happy? [from rule (B)]  
 c. \*Is the man who \_\_ tall is happy? [from rule (A)]

Their point is that, if children could access all possible types of formal systems to make hypotheses about what is going on in (1b), they could make several simple structure-independent hypotheses, such as (A). There are many other possibilities, such as those in (3) — if we make the “reasonable” assumption that children encounter declarative sentences like (1a) first, as Crain (1991: 602) puts it.<sup>4</sup>

- (3) a. Move an occurrence of *is* to the front of the sentence.  
 b. Move the last occurrence of *is* to the front of the sentence.

These two hypotheses derive the correct order (2b), but (3a) also derives the incorrect order (2c), and (3b) produces the incorrect order (4b) from (4a).

- (4) a. The man is happy because it is sunny.  
 b. \*Is the man is happy because it \_\_ sunny.

Yet children do not make errors like these, even though the data of experience are too poor to select the correct hypothesis. The standard account is that humans have an innate principle of “*structure dependence* of grammatical rules generally, including rules of question formation” (Berwick & Chomsky 2008: 383).

Chomsky (2010a, 2011) tries to go further and to provide a more principled explanation of these facts. He addresses two questions not previously raised in the traditional literature on structure dependence. First, why is there structural instead of linear locality in grammar?

Suppose it can be shown that linearization is never required for interpretation at CI (conceptual-intentional). Then we would expect it to be introduced solely as a reflex of SM (sensory-motor), where it is plainly needed. That would carry us a step farther towards answering the How and Why questions that remain for Aux-inversion: minimal structural distance (structure-dependence) is the only option (given the third factor consideration MC, Minimal Computation): linear order is simply not available to the computational system at the point where the C-inflection relation is established. (Chomsky 2011: 274)

However, some facts are problematic for the general assumption that linearization is not relevant in semantic interpretation. For instance, Wasow (1979: 36) proposes the Novelty Condition — that an anaphorically dependent element cannot have more determinate reference than its antecedent — in order to account for the facts in (5):

- (5) a. A doctor<sub>i</sub> walked into the room. The man<sub>i</sub> at first said nothing.  
 b. \*A man<sub>i</sub> walked into the room. The doctor<sub>i</sub> at first said nothing.

---

<sup>4</sup> This assumption should be checked carefully, as children are very frequently exposed to interrogatives.

True, linear order comes from the sensorimotor system: “[T]he structure of our sensorimotor system is such that we can’t speak in parallel. We just speak linearly” (Chomsky 2010a: 10).<sup>5</sup> But this linearity is internalized in our brain: Production and perception of the linear arrangement of elements is not purely physical. Linearity must be internalized, otherwise words/signs as we know them would be impossible. A word/sign is a link between a concept and a perceptual form, a *signifié* and a *signifiant* in Saussure’s terms. Without a perceptual form associated with it, a concept is just a concept: it only becomes a meaning — a linguistic element — when it is linked with a perceptual form. So a word is defined in part by its phonological substance, including the order of its phonemes. The internal representation of these phonemes and their ordering is a crucial distinguishing feature of a word. Consequently, some internal linear properties of words are available all along derivations, including when the computational system merges two lexical items A and B in syntax: Since each word has indications on how to linearize its phonemes in the motor system, the linearized phonemes of A will necessarily have to be linearized with respect to those of B. In the case at hand, it is most likely that some aspects of order of the Tensed verb are available to the computational system at the point where it processes Tense.<sup>6</sup> So the question why there is structural instead of linear locality is not answered.

The second question that Chomsky raises is why it is the Tense of the main clause that moves to C, and not some other element, such as the head of the NP subject, for instance. Assuming that structural locality is relevant, the answer must be that T is structurally the closest node to C. However, the subject in Spec of T is at least as close to C as T. Chomsky obtains the effect that T is nevertheless closer to C by assuming that the subject is not there when T and C are related. Though the subject obligatorily surfaces in Spec of T, it is initially generated internally to VP and is raised later. This appears to be counter-cyclic, but is solved by assuming that CP is a phase but not TP; so the raising of the subject out of VP to T is in the same phase as the movement of T to C: The subject will not be in the way if it moves out of VP only after T has moved to C.

If we try to replicate the experiment, i.e. the derivation, we realize that there are several implicit assumptions in this analysis for which there are no evident principled explanations. Thus, the following stipulations are required:

- i. Something must move in C when a sentence is a polar interrogative.
- ii. T moves to C before the subject NP moves to the T position.
- iii. CP is a phase but not TP, i.e. in any movement analysis, minimal distance involves specifying what counts as a barrier node.
- iv. Though the verbal phrase sister of T is as close to C as T is, T is the target of movement. (See Chomsky (2007b: 16): Why does the full *v*\*P never raise?)

---

<sup>5</sup> This, of course, is Saussure’s (1916) *Principe de Linéarité*.

<sup>6</sup> Assuming that the system can somehow temporarily “forget about” phonemes and linearity creates a severe problem. The system must be able to retrieve this material later in the derivation to provide a complete surface string for a sentence. It is rather unclear what it means for features to be in limbo for part of the derivation, and how this really restricts the functioning of the system, since the features are nevertheless kept in this obscure storage facility. Actually, adding a novel storage facility to the system makes it more complicated.



As things stand, these stipulations have no discernible principled explanation and have the status of UG statements. Some of these stipulations are dependent on the particular analysis that Chomsky (2010a, 2010b) proposes, and they can be seen as fairly innocuous details to be worked out in his newly proposed analysis. But there are four more constraints that have been implicit in all arguments for structure dependence.

*Constraint (i):* The rule targets the Tense of the sentence.

The target is Tense, not the word *is*, nor AUX. Thus, when there are two auxiliary verbs as in (6a), tensed AUX is fronted as in (6b), not the other AUX.

- (6) a. John has been reading.  
 b. Has John been reading?  
 c. \*Been John has reading?

Moreover, when there is no AUX as in (7), *do*-support isolates Tense from the verb and only Tense is fronted.

- (7) a. John ate the apple.  
 b. Did John eat the apple?  
 c. \*Ate John the apple?

Without constraint (i), the learner could erroneously assume that you move some element to form a question, any element at all.

- (8) a. The man is happy today.  
 b. \*Today the man is happy?  
 c. \*Man the is happy today?  
 d. \*Happy the man is today?

*Constraint (ii):* The Tensed element ends up in a particular position, outside the basic sentence (i.e. TP).

Without constraint (ii), the child could make the error of moving Tense to any other positions in the structure. This can be attributed to the presence of a Q-marker on Comp (Baker 1970) that attracts Tense to check it, but that bluntly restates the facts and does not explain why anything at all must be in that position in polar interrogatives. As Chomsky (1995) remarks generally, this kind of formulation, “is a restatement of the basic property, not a true explanation” (p. 233) and “the sole function of these feature checkers is to force movement” (p. 278). Stating that the movement is due to the requirement of checking the Q-feature pushes the stipulation deeper in the system but does not dispose of it.

*Constraint (iii):* The phenomenon is restricted to main clauses.

Without (iii), the embedded Tense could be targeted and fronted to the embedded Comp (9b), or to the main clause Comp (9c).

- (9) a. Mary said the man is happy.  
 b. \*Mary said is the man \_\_ happy? [not direct discourse]  
 c. \*Is Mary said the man \_\_ happy?

There is another constraint that is implicit in the discussion: This change in word order produces a sentence with a different meaning.

*Constraint (iv):* The special word order correlates with a question meaning.

Without (iv), the child could just “play” with the rule, with no change in meaning as in (8).

Chomsky (2010a, 2010b) tries to explain away Constraint (i) by having T in the most prominent structural position in the sentence. However, this is obtained at the cost of adding stipulations (i) to (iv) to the theory, so on the whole there is no clear progress here. As for Constraints (ii), (iii) and (iv), he implicitly assumes them like everyone else. Therefore, in this analysis, we have no answer to the basic question: Why does the tensed verb appear in a particular position?

These appeals to UG preclude the analysis from providing a principled explanation of the facts. The four constraints above and structure dependence are roughly of the same degree of complexity as what they are supposed to account for: They restate in technical terms what the facts are. However, we are not told *why* these particular facts hold: Why is Tense involved in question formation? Why is it only the Tense of the main clause? Why does having Tense in Comp correlate with a meaning of polar interrogative? We are just told that these facts correlate with random system-internal features and constraints. The constraints have to be stipulated, listed in UG, because they follow from nothing. Science is not merely interested in what is, in inventories of facts and assertions of existence (regardless of how crafty the formulations may be); science is mostly interested in why things are as they are, in modalities of what is possible. It may be that these “system-internal constraints [...] are efficacious in forestalling wrong turns a child might otherwise take” (Crain 1991: 602), but they are quite inefficient in elaborating an explanatory scientific theory, precisely because they are system-internal and have no independent, external motivation.

### 3. Structure Dependence and the Facts

#### 3.1. Constraints on How, but Not on What Can Be Attained

Not only is structure dependence conceptually weak, it also fails empirically to explain even the wildest cases. For instance, no human language forms questions by linearly reversing the word order of a declarative. Though this is usually presented as a far-fetched possibility, it is actually feasible if the only condition is structure dependence. Consider how Cinque (1994, 2010) derives the mirror order of adjectives in French *vase chinois bleu* from the structure reflected in the English order *blue Chinese vase*.

- (10) a. basic structure in order predicted by LCA: *bleu chinois vase* →  
 b. movement of N: *bleu vase chinois* →  
 c. remnant movement of N+ADJ: *vase chinois bleu*

First, the N is raised as in (10b). Then a phrase WP that contains *vase chinois* is moved above *bleu* to the Spec of some category Z that has an uF that happens to attract phrases like WP. With tools like these, it is possible to save the LCA whenever it does not directly predict the correct scope of Adjs (see an extensive discussion of what this analysis implies in Bouchard 2002, 2011). By appropriately setting the features, tools like move and remnant move can just as easily have structure-dependent derivations for questions that reverse the word order of a declarative. The derivation can even be better motivated than in the case of adjectives. For instance, consider the assumption that an interrogative sentence like (1b) has a Q-marker in Comp that attracts the tensed verb. In addition, the sentence has a specific interrogative intonation. Kegl *et al.* (1996) assume that this intonation is anchored in the Comp with a Q-marker and it spreads over the structure (but see Bouchard 1996). Since the Q-marker in Comp can trigger the movement of a Q-feature checker (Tense) and the specific intonation, a child can make the “natural” analogy that the Q-features that spread on every constituent, phrasal or terminal, can each trigger movement.<sup>7</sup> So in (11), the Q-marked *money* locally adjoins to the local DP to check its feature with the Q-feature of *the*: this eliminates the Q-features of *money* and *the*, but leaves the feature of the DP untouched; the Q-marked DP then locally adjoins to the VP to check its feature with the Q-feature of *took*; finally, the Q-marked VP locally adjoins to the DP to check its feature with the Q-feature of *John*.<sup>8</sup>

- (11) John took the money →  
 John took **money** the →  
 John **money the** took →  
**money the took** John

Of course, the derivation could be made much more complex under other assumptions. Details like these aside, the main point is that, even with structure-dependence and constraints (i) to (iv), the analytical tools that we commonly find in various analyses of other data allow us to derive constructions that are impossible in any language. Structure dependence restricts how the child can invert the order of words, i.e. it proscribes doing it by applying a linear rule, but it does not prevent the child from inverting the order as in (11). So structure

<sup>7</sup> Sportiche (1995) assumes that the Q-marker that triggers the rising intonation in the French intonational questions (i) also triggers a movement, i.e. the raising of the whole IP to the Spec of the Q-morpheme.

(i) Tu aimes ce livre? French  
 ‘You like that book?’

<sup>8</sup> There are abundant examples of this kind of derivation with remnant movement in the Cartography project, some with even more complexity. See for instance the analyses of adverbs in Cinque (1999) and of DP and IP in Cinque (2002), the derivation of possessive constructions in Kayne (2006) and *of*-phrases in Kayne (2002).

dependence fails empirically. In fact, just about anything is possible under those assumptions. For instance, suppose that the direct object is fronted instead of Tense in polar interrogatives in a language: This would ‘demonstrate’ that constraint (i) is parameterized between Tense and direct object, i.e. languages choose which of the two is a Q-feature checker (or alternatively the direct object ends up closer to Comp in that language because it is forced to check some agreement features early). If Tense moved to a position other than COMP, you only have to change the list of landing sites: The Q-marker would also appear in another position (or Tense nevertheless moves to Comp but covertly). If Tense moved out of embedded clauses in some language as in (9c), escape hatches could easily be provided, as in the many cases where movement theory assumes movements out of complement clauses, i.e. *wh*-movement, subject raising, long head movement in some Balkan languages (Rivero 1994 and references therein). We could also appeal to Relativized Minimality (Rizzi 1990): If we discovered a case of a polar interrogative with AUX Inversion in an embedded clause, this would ‘demonstrate’ that only the embedded Tense has the crucial Q-feature. Berwick *et al.* (2011: 1230) strongly criticize Perfors *et al.* (2011) because they do not “explain why *Is the boy who lost left* fails to have the following interpretation: (is it the case that) the boy who is lost left?”. But Berwick *et al.* fare no better in their account of this fact, if you look at the whole system. The subject being higher than Tense in the structure, the system can determine that the Tensed AUX inside the relative clause of the subject is the closest Tense to Comp, assuming that all the other elements in the subject are irrelevant under Relativized Minimality. The reason why that sentence does not get this erroneous interpretation in their system is due to assumptions like the subject is not yet high in the structure when T moves to Comp. This is an ad hoc ordering of the Subject Raising transformation after the Tense Raising transformation: there is no other reason to assume this ordering but the end result. Compare this with the free ordering of the raising of two quantifiers (May 1985): Assuming that the subject must raise and Tense must raise, both in the same phase, the two orderings of rules should be equally possible, and is only ruled out by blunt stipulation.

All of this and much more is possible in the movement analysis because these constraints are random facts, which therefore could be replaced by other random constraints in UG. Given current assumptions in minimalism, the grammars produced from these tools overgenerate radically.

### 3.2. *Crosslinguistic Variation in Question Formation*

Contingent constraints also fail to provide an informative account of crosslinguistic variation in question formation. Some languages indicate that a sentence has a question interpretation by means other than a special order. For instance, Québec French and Korean express the illocutionary force of interrogation not by putting Tense in a special position but by marking the Tense of main clauses with a Q-particle, *-tu* and *-ni*, respectively.<sup>9</sup>

---

<sup>9</sup> An interrogative particle is found in several varieties of French, varying in form between *-tu* and *-ti*. It historically comes from a reanalysis of the sequence *t-il* in questions like (i):

- (12) a. Paul a-**tu** fini? *Québec French*  
*Paul has-QP finished*  
 'Has Paul finished?'  
 b. Je fais-**tu** ça correctement?  
*I do-QP this correctly*  
 'Am I doing this correctly?'
- (13) Chelswu-ka mues-ul po-ass. *Korean*  
*Chelswu.NOM INDEF.ACC see.PAST*  
 'Chelswu saw something.'
- (14) Chelswu-ka mues-ul po-ass-ni. *Korean*  
*Chelswu.NOM INDEF.ACC see.PAST.QP*  
 i. 'What did Chelswu see?'  
 ii. 'Did Chelswu see something?'

The sequence in (14) is interpreted either as a yes/no question or as a question bearing on *mues-ul*. The two interpretations correspond to different intonations: The intonation peak is on the subject or the verb under the yes/no question interpretation, whereas an intonation peak on *mues-ul* results in a questioned-phrase interpretation (Cheng & Rooryck 2000). So instead of the positional strategy used by English to provide a signifiant for the illocutionary force of polar interrogative, Korean uses the morphological marking *ni*, and yet another signifiant — intonation — to distinguish between the existential and interrogative interpretation of *mues*. The option of intonation that our physiology provides as a signifiant is also used in French, as in (15), where a particular rising intonation suffices to express the illocutionary force of interrogation.<sup>10</sup>

- (15) Jean a acheté un livre? *French*  
*Jean has bought a book*  
 'Has Jean bought a book?'

Particle marking and Q-intonation show that Tense is not targeted for either linear or hierarchical proximity to Comp: Tense is targeted because of its

- 
- (i) Pierre mange-t-il? *French*  
*Pierre eat.3.SG -he*  
 'Does Pierre eat?' or 'Is Pierre eating?'

<sup>10</sup> The fact that a rising intonation encodes interrogative force may be related to the fact that in many languages, an intonational rise signifies incompleteness, whereas an intonational fall indicates completeness (Vaissière 1995, Bouchard 2002: 375–376). For instance, when a speaker enumerates the items of a list, a rising intonation on an item (represented as <) indicates that the enumeration is not completed, whereas a falling intonation on the last item signals completeness.

- (i) a. Il y avait Paul<, son frère<, ses soeurs<, et sa mère.  
 b. There was Paul<, his brother<, his sisters<, and his mother.

This may explain why an intonational rise is frequently used to signal polar interrogatives: It indicates that the discourse is not completed, hence it is a request to complete the information.

meaning. Of course, it is always possible to add elements to the theory to maintain that Tense is targeted for its hierarchical proximity to Comp. One could propose that the Q-intonation is anchored in the Comp with a Q-marker and spreads over the structure, as Kegl *et al.* (1996) assume, and assert that the interrogative particles *-ni* and *-tu* (and for good measure, the Q-intonation), trigger the movement of Tense to the Comp with a Q-marker, but covertly in these cases. One could then claim that this Q-marker captures a generalization about the role of Comp in all polar interrogatives. However, this is a false generalization: In so doing, we are not capturing a generalization but creating it, at a cost. This is similar to a putative universal that Morris Halle used to discuss in his classes: Every word of every language ends with the phoneme /a/. This universal is validated by the fact that many words do end in /a/. What about all those words that do not? With a twinkle in his eye, Morris would say that this demonstrates that there is a rule (or several) that deletes the /a/ (or prevents it from being pronounced) under certain conditions. Our job as linguists is to figure out what those conditions are. Of course, Morris was just illustrating how easy it is to create false generalizations, with auxiliary hypotheses to save the day. Note that his false generalization is better substantiated than the one about the Q-marker in Comp: Every language has at least a few words that end in /a/, whereas most (if not all) languages fail to show a surface, pronounced Q-marker in Comp.

There is another way in which languages vary in question formation: Languages do not target Tense in the same way. In English, only AUX (*be, have, modals*) or dummy *do* are targeted, whereas in French, in addition to AUX (*être, avoir*), lexical verbs can also be involved in various complex ways.

- (16) a. L'enfant aimait ce jouet. *French*  
       'The child liked that toy.'  
       b. L'enfant aimait-il ce jouet? Pronoun copy  
           *the child like-he that toy*  
           'Did the child like that toy?'
- (17) a. Il aimait ce jouet. *French*  
       'He liked that toy.'  
       b. Aimait-il ce jouet? Pronoun-verb inversion  
           *liked-he that toy*  
           'Did he like that toy?'

This difference between the two languages comes from the way the grammar of a language can deal with a syntactic head that has multiple functional specifications marked by its morphology. For instance, how can a Verb+Tense word such as *liked* or *aimait* function? There are two logical possibilities. First, they may function as a unit, so whatever is under the scope of T or V is also under the scope of the other, and whatever has scope over T or V also has scope over the other. Second, they may function independently from one another: Something under the scope of the head may be under the scope of T or V without being under the scope of the other, and something with scope over the complex head may have scope over T or V without having scope over the other.

English functions as in the first case, so *do*-support is required to separate the main verb from Tense when only Tense is targeted as in polar interrogatives. French exhibits the second possibility. We see this in portmanteau words such as *du* ‘of.MASC.SING.DEF’, *des* ‘of.PLUR.DEF’, *au* ‘to.MASC.SING.DEF’ and *aux* ‘to.PLUR.DEF’: These words have features of both a preposition and a determiner, and the sets of features appear to interact with other constituents independently from one another. Thus, in *aux enfants* ‘to the children’, *aux* expresses both the features of a preposition (*à*) that has a DP argument and the features of the Det (definite plural). This portmanteau effect in French, and its absence in English, explains why Tense is not targeted in the same way in these two languages. For instance, if *not* must have scope only on the verbal (predicative) part of the sentence and not on Tense, this explains the presence of *does* in (18), which removes Tense from the scope of the negation.

(18) Mary did not eat peanuts.

(19) Marie ne mangeait pas d’arachides. French  
 Marie NEG eat.PAST not of peanuts  
 ‘Marie did not eat peanuts.’

In French, *pas* is the negative element and the particle *ne* indicates the scope of the negation. So negation has scope over *mangeait*, but the portmanteau effect allows negation to scope over the verbal part *mang-* without scoping over the Tense part *-ait*. The same effect is found in the polar interrogative in (17): The whole form *aimait* is generated in Comp, but only the Tense part *-ait* is relevant for the polar interrogative interpretation. The equivalent sentence in English is ‘*Did he like that toy?*’ and it requires *do*-support. See Bouchard (1995: sect. 5.4) for a detailed account of variations like these. In particular, whereas adverb placement is just a correlation with ad hoc features in the movement analysis (Emonds 1978, Pollock 1989, Piattelli-Palmarini & Uriagereka 2004), in the portmanteau analysis, it follows from the necessity to choose how to analyze V+T, a parameter that derives from the junction point between syntax and morphology.

#### 4. UG Meets Semantics

Insofar as a model based on structure dependence is intended to cover such cases and explain such facts as those presented in the previous section, and it fails to accommodate them, and so do approaches based on claims of a better learning capacity or richer data, this indicates that a feature common to all these models is seriously amiss. These approaches are all based on the generativist description of what is going on: they assume that the generalizations and ‘laws of grammar’ that generativists discovered are roughly empirically correct. But facts, i.e. observational propositions, are part of a theory, they are not external to it and independent (Lakatos 1970): Their status can be questioned in the face of an overwhelming problem. A residue of unexplained elements that will not go away for 50 years is indicative of a serious problem. It may well be that what generativists claim that children know requires several domain-specific devices like those

listed in UG, but that is irrelevant because that this is not what children know, as I will now argue for subject–AUX inversion (For reasons of space, I cannot look at more cases here, but see references at the end of the conclusion). Under the view that Tense moves when there is subject–AUX inversion, the two options of particle marking and Q-intonation, as well as the four constraints (i) to (iv) and structure dependence, are accidental properties: They do not seem to be derivable one from another and each requires a stipulation. This weakness comes from the fact that this view neglects an important aspect of what is learned: The semantics of the construction, the fact that each order in (1) correlates with a different meaning. If children are only exposed to the difference in linear order in (1a–b), it may be that they do not have access to data rich enough for some inferential techniques to determine what is going on in their language. But by the context of use, they are also exposed to the difference in meaning between these two sentences.<sup>11</sup> Crucially, bringing in the semantics of the sentences changes the picture of what is going on to a point where the syntax of (1a–b) is not at all as represented in the transformational analysis: The movement analysis gets in the way of figuring out what children learn. “Chomsky’s arguments, and mathematical evidence of unlearnability of syntax, made fundamental assumptions about *what* is learned that merit closer scrutiny. In particular, they assumed that syntax is independent from meaning, and that the task for the learner is to identify rules that generate legitimate strings of syntactic elements and that do not generate illegitimate strings” (Bishop 2009: 188). But children do not learn those kinds of rules, they do not learn that transformations apply under particular constraints in constructions like (1a–b): They learn that a different order comes with a different meaning (see Matthews 1993: 211–214 on the unjustified conflation of generative grammars with what a child allegedly knows).

Let’s look at the facts in a more theory-neutral way. What do learners ‘realize’ in comparing (1a–b)? That the Tensed auxiliary *is* can appear in two different positions, and the meanings of the two resulting sentences are different. Is this a reason to postulate a transformational rule? In English, a difference in word order usually correlates with a difference in meaning. In generative grammar, it is assumed that there are two kinds of these correlations between positions and meanings, and they have two different syntactic derivations. First, a movement analysis is proposed when an element appears ‘displaced’ from where it is interpreted, as in (20), where the sentence-initial *wh*-phrase is interpreted as the direct object of *kiss*.

---

<sup>11</sup> Slobin (1975: 30) offers an important reminder on the matter:

Most studies of child language comprehension put the child into a situation where there are no contextual cues to the meaning of utterances, but in real life, there is little reason for a preschool child to rely heavily on syntactic factors to determine the basic propositional and referential meaning of sentences which he hears. Judith Johnston and I have gone through transcripts of adult speech to children between the ages of two and five, in Turkish and English, looking for sentences which could be open to misinterpretation if the child lacked basic syntactic knowledge, such as the roles of word order and inflections. We found almost no instances of an adult utterance which could possibly be misinterpreted. That is, the overwhelming majority of utterances were clearly interpretable in context, requiring only knowledge of word meanings between actors, actions, and objects in the world.



(20) Who did John kiss?

The second type of correlation between positions and meanings is the one that speakers learn when they are exposed to pairs as in (21).

- (21) a. John saw Mary.  
b. Mary saw John.

The correlation in (21) is systematic: If *John* is in position A, it is interpreted as the one who sees; if *John* is in position B, it is interpreted as the seen one.<sup>12</sup> The question is whether Tense in the question (1b) is interpreted in the same way (in the same position) as it is interpreted in the declarative (1a), hence a case of movement as in (20), or the pair in (1) is an instance of an element appearing in a different position with a different interpretation as in (21). In order to determine this, we must figure out how Tense contributes to the meaning of the sentences in (1a) and in (1b).

We can describe the meaning and form alternations in (1) in terms of the notion of ISSUE. Ladusaw (1996), following ideas of Frege and Davidson, proposes that the main predication expressed by a sentence is a description of a class of events and this description is the ISSUE about which we must make a judgment. In an affirmative declarative sentence like (1a), the speaker expresses a positive judgment by placing the syntactic counterpart of the ISSUE under the immediate scope of the deictic Tense, i.e. the Tense of the main clause that is determined with respect to the moment of speech, with respect to ‘reality’ (Bouchard 1998, 2002). It is a typical property of (main) sentences that they are obligatorily tied to our indexical system of immediate experience by means of a deictic element. This deictic anchoring is presumably required to establish the truth conditions of the sentence. Though Tense is by far the most frequent deictic anchor, some languages anchor their sentences with deictic Location or Person instead (Ritter & Wiltschko 2009).<sup>13</sup> Because this deictic element relates to the event of the whole sentence, it is a prominent element in the set of combinatorial relations of the sentence: That is why scholars who represent these relations in terms of hierarchical structure intuitively put this deictic anchor at the head of the sentence, with the syntactic counterpart of the ISSUE — the VP — as a complement of Tense. As is well known, one of the arguments — the subject — is external to the VP. This comes from the fact that the relation between the deictic anchor and the ISSUE is forced to be less direct than a simple combination of Tense and the VP. As indicated in Bouchard (1995: 168), an event is a relationship between various actants, whereas Tense identifies a point in time. Event and point in time cannot be directly related because they are ontologically different:

<sup>12</sup> The idea that the order of two constituents is a possible signifiant seems to have been part of Saussure’s thinking, though he never developed it in any detail. For instance, in Bouquet & Endler (2002: 48), Saussure alludes to a sign that consists in placing a certain sign before a certain other.

<sup>13</sup> Young English speaking children often use verbs without Tense in simple clauses, in violation of the adult grammar of their language. This is most likely because their utterances are not detached from the immediate environment in the early stages of language acquisition, so they are ostensibly linked to it without recourse to a deictic element.

One is a point, the other a network of points. The relation is therefore established between the point in time and one of the points of the event, one of its actants, the subject. The subject is this privileged actant from whose perspective the event is related to time, as determined by lexical specifications of the verb. By situating the subject with respect to the temporal point, the network of relations that the subject entertains with the other actants — the ISSUE — is also situated. This explains the two particular relations that Tense establishes in a sentence. On the one hand, Tense appears in a close combination with the predicative part: Either it combines syntactically with the VP or morphologically with its head. On the other hand, the result of this first combination in turn combines with the subject (in hierarchical terms, the subject is the specifier of that constituent).

This analysis provides a principled explanation to the special status of the subject argument (instead of listing the peculiar property as a special feature like EPP), because it is based on an externally motivated factor (what Chomsky 2005 refers to as a ‘third factor’). The notion of principled explanation is important on general grounds. As Lakatos (1970) remarks, some scientific propositions are considered to be external because they are logically prior to the object of study, since this object presupposes them. In linguistics, the most basic observational proposition given the status of initial condition is that language is a system that links concepts and percepts. Therefore, language is determined by the subsystems that govern these elements, namely the conceptual system found in human brains, and the sensorimotor systems of human bodies. Since the properties of these subsystems are presupposed by the definition of the object of study of linguistics, the linguistic community deems them to be self-evident, determined by logically prior sciences. Thus, the sciences that account for acoustics, the physics of articulation, the cognitive aspects of how humans conceptualize the world, and so on, are given an observational status. For instance, Tesnière (1959) (following Saussure 1916), Kayne (1994), Bouchard (2002) argue that some phrasal structural properties can be derived from the observational proposition that words must be ordered in oral languages because our articulatory system does not allow the production of two words simultaneously. The explanation for this linearization does not lie in linguistic theory, but rather in whichever science accounts for properties of the articulatory apparatus of human beings that produces the sounds of language. In analyzing a language with a different modality such as a sign language, it is therefore crucial to take into account the differences in linearity/simultaneity, among others, as argued forcefully in Bouchard & Dubuisson (1995) and Bouchard (1996). Properties of the conceptual and perceptual substances provide a strong basis of explanation because it is possible to relate the explanandum to an explanans that is independently motivated since it comes from domains that are logically prior to language.<sup>14</sup>

---

<sup>14</sup> In the Minimalist Program, minimal computation is by far the ‘third factor’ that is most typically called on. However, efficient computation may be the least sound basis for explanation. At the formal level of the elaboration of a theory, it is efficacious to have a theory that satisfies conditions of simplicity and non-redundancy. But maximal efficiency does not appear to be adequate to explain natural phenomena (Johnson & Lappin 1999). In biological systems, efficiency is typically a mix of economy and redundancy to insure robustness. Language also is typically replete with redundancies. For instance, the fact that the expression is feminine is indicated three times in (i.a); the fact that the subject is first

In contrast with a declarative sentence, in an interrogative like (1b), the deictic Tense is expressed outside of the extended syntactic counterpart of the ISSUE, i.e. the VP plus the subject. In hierarchical terms, Tense is in the position where we find complementizers. Evidence for the Comp position comes from the fact that the sentence-initial placement of the tensed verb is not compatible with the presence of a complementizer. For instance, French has two types of exclamatives, one with inversion (22a) and one with a complementizer (22b); however, the two never co-occur (22c) (Goldsmith 1981).

- (22) a. Est-elle belle!  
 b. Qu'elle est belle!  
 c. \*Qu'est-elle belle!

In languages that allow 'doubly filled Comp' such as Québec French, *wh*-interrogatives can involve inversion of the tensed verb as in (23a) or filling the position with complementizer *que* as in (23b); however, it is not possible to have both the tensed verb and *que* preceding the subject as in (23c-d).

- (23) a. À qui as-tu parlé? Québec French  
 'To whom have you spoken?'  
 b. À qui que tu as parlé?  
 'To whom that you have spoken?'  
 c. \*À qui qu'as-tu parlé?  
 'To whom that have you spoken?'  
 d. \*À qui as que tu parlé?  
 'To whom have that you spoken?'

The fact that Tense is in Comp in interrogatives means that it holds a different relation with the ISSUE, and this affects the interpretation. In Bouchard (1998, 2002), I suggest that with Tense outside (in COMP), the ISSUE is presented as being separated from Tense, as not being established. This induces a polar interrogative interpretation, a request to know whether the ISSUE should be considered established or not. Under this view, Tense is not moved to COMP. Instead, Tense is generated as combining externally, with the whole sentence, in contrast with the two internal relations with the VP and the subject that occur in affirmative clauses.

This external combination is possible because [Tense + ISSUE] is an inter-

---

person plural is marked twice in (i.b); the interrogative meaning is expressed by both a particular word order and a particular intonation in (i.c).

- (i) a. La petite chatte.  
       *the.FEM small.FEM cat.FEM*  
 b. Nous marchons  
       *Pronoun.1.PL walk.1.PL*  
 c. Are you coming?

To reconcile linguistic theory with the potential biological messiness of language, it is more fruitful to appeal to the other components of the third factor, namely the design properties of the conceptual and perceptual properties of signs.

pretable syntactic combination, whereas [Tense + N], or [Tense + Det], etc. are possible syntactic combinations, but they are not interpretable (no more than V as Spec of N etc.), so these combinations do not occur. There isn't a *rule* of question formation, and the notion of construction has no status in the theory: There is a combination Tense + ISSUE which results in polar interrogative interpretation. There isn't a movement involved in (1b) because Tense entertains a single relation with the ISSUE, different from the ones in the declarative (1a). What is going on is not fronting as in rules (A) or (B) of Berwick & Chomsky (2008), but rather rule (C).

(C) Merge deictic Tense from outside with the whole ISSUE (VP plus subject).

Tense is generated there directly, it does not move from another position, no more than *John* or *Mary* in (21). As expected, other deictic anchors function like deictic Tense in questions. Thus Ritter & Wiltschko (2009) observes that in yes/no questions in Halkomelem, the locative AUX *li* appears in Comp. Here too presenting the ISSUE as not deictically established results in a polar interrogative interpretation.

In short, Merge applies freely, and declaratives and interrogatives involve two ways of merging Tense that result in structures that are interpretable. A system with free Merge permits radical overgeneration, but in general this is not a problem since the ungrammatical combinations are filtered by selection restrictions, as indicated in Bouchard (1979, 1982, 1984, 1991). This is a principled explanation since it is a foundational notion that words and constituents have meanings, and a selection restriction results from the compatibility of these primitive properties. Grimshaw (1979) and Pesetsky (1982) were among the first generativists to argue that the semantic primitives are epistemologically prior to the primitives of c-selection.<sup>15</sup> However, some matters remain unclear concerning Tense. There is a restriction on what Tense can merge with (at least in English and French): The element must morphosyntactically be verbal. Though event DPs and small clauses may also be construed as descriptions of events, they do not make good interrogatives, as a reviewer pointed out (24). Of course, they also do not make good declaratives (25).

- (24) a. \*Did [ the emperor's death ]?  
b. \*Did [ the emperor dead ]?

- (25) a. \*The emperor's did death.  
b. \*The emperor did dead.

---

<sup>15</sup> There are also many attempts to constrain free Merge syntactically, but they are descriptive, not explanatory. For instance, Svenonius (1994), Holmberg (2000), Adger (2003), Di Sciullo & Isac (2008), assume that lexical items have categorical features that must be checked against the categorical feature of selected objects, and that this checking is a defining condition on the application of Merge. This added mechanism is costly and purely descriptive. As Koster (2009: 8) remarks, this is no progress from Chomsky (1965), since Merge essentially functions like a Phrase Structure rule: Lexical items have features that say what kind of element they take as a sister. Moreover, c-selection features do not extend straightforwardly to the merger of adjuncts, since an adjunct is not selected by a lexical item.

So some finer distinction must be made between the ISSUE of a VP and the semantics of event DPs and small clauses that will explain why only the former is compatible with the semantics of Tense. For now, I do not know what that difference is, so I will leave it as a descriptive restriction in wait of a principled account.

We now see why all the properties described in the constraints above are interrelated in questions. (i) Tense is involved because of its relation with the ISSUE. (ii) Tense is in Comp because in that position it establishes a particular semantic relation with the ISSUE. (iii) The Tense of the main clause is involved because the ISSUE is a matter of the utterance, of the main predication of the whole sentence.<sup>16</sup> (iv) The interpretation results in a polar interrogative meaning because the combination [Tense + ISSUE] presents the ISSUE as not being established. Together these properties have the effect that, in a displacement analysis, the movement of Tense appears structure dependent. But this is an illusion. Question formation is not structure dependent, it is meaning dependent.

What learners realize when exposed to (1a–b) is that if Tense is in a sentence-internal position, it is interpreted as establishing the ISSUE with respect to deictic time, and if Tense is in a position external to the ISSUE, it is interpreted as not establishing the ISSUE. Learners expect these kinds of correlations because, given Saussurean arbitrariness, they are conservative about order and do not mess with it in order not to lose the systematicity of what it conveys: As with signs in general, a difference in form is expected to correspond to a difference in meaning, and vice-versa. They will normally need rich, positive evidence before they use a different word order, such as a meaning difference, just as they learn other position-meaning correlations with the phonemes of lexical signs, and the order of arguments like *John* and *Mary* in (21), of pre- and post-nominal adjectives in French, and countless other examples.<sup>17</sup>

As expected, the juxtaposition of the Tense-bearing head with the whole ISSUE-constituent (VP plus subject) is not the only possible signifiant to express this particular relation between Tense and the ISSUE: Some languages use other signifiants, such as marking Tense with a dedicated particle, or superimposing a particular intonation on the whole projection of Tense, as we saw in (12) to (15).<sup>18</sup>

<sup>16</sup> According to Henry (1995), inversion is also possible in embedded interrogatives in Belfast English, as in (i):

(i) She wonders had she picked the dish.

This may be due to a Celtic influence. It would be interesting to look into the Tense system of Belfast English to see if the embedded Tenses can be deictic, directly tied to the moment of speech, instead of indirectly through a concordance with the Tense of the main clause.

<sup>17</sup> Given conservatism (a well-motivated principle on evolutionary grounds), Schoenemann (2005: 65) argues that

positive evidence can actually be used as a weak form of negative evidence (i.e. “if this form is correct, then another is unlikely to be correct, barring future positive evidence to the contrary”). Chomsky (1981) has pointed out that if children notice that “...certain structures or rules fail to be exemplified in relatively simple expressions, where they would be expected to be found, then a (possibly marked) option is selected excluding them in the grammar, so that a kind of ‘negative evidence’ can be available even without corrections, adverse reactions, etc.” (p. 9). Regier (1996) showed that this can be implemented for learning word meanings as well.

<sup>18</sup> Hurford (2011: 278–279) also proposes a semantic approach to structure dependence in Subject–AUX inversion, but it differs significantly from the one proposed here. The key for him is that

## 5. Empirical Arguments to Move Tense?

It could be argued that we must assume that Tense moved in (1b) because the Tensed verb in Comp exhibits displacement properties with respect to selection and agreement. For instance, the modal *can* is semantically associated with *eat* in (26a), not with *fly*.

- (26) a. Can eagles that fly eat?  
 b. Can [[eagles that [ $v^*$  [fly]]] [ $v$  [eat]]]?

Chomsky (2011) and Berwick *et al.* (2011) follow the generative tradition and assume that when words separated in a string exhibit semantic/phrasal relations that are prototypically exhibited by adjacent words, there is a step in the derivation where the ‘displaced’ constituent is in that position. So there is a step in the derivation of (26) where *can* is in the position represented by *v*. Originally, Chomsky (1957) observed some systematic similarities between sentences such as declarative-interrogative pairs, active-passive pairs and declarative-wh-question pairs, and he argued that these regularities were difficult to capture with phrase structure rules. He suggested that the similarities were due to a common underlying structure, to which each of the sentences was transformationally related. “The general problem of analyzing the process of ‘understanding’ is thus reduced, in a sense, to the problem of explaining how kernel sentences are understood, these being considered the basic ‘content elements’ from which the usual, more complex sentences of real life are formed by transformational development” (Chomsky 1957: 92).<sup>19</sup>

---

children surely must be [concerned] with making communicative utterances. When a child asks a question, she usually has a referent in mind that she is interested in finding out about. That’s why she asks the question. *Is Daddy home yet?* is a question about Daddy. The natural thing for a child learning how to ask questions in English is to realize that you put an expression for the person or thing you are asking about just after the appropriate auxiliary at the start of the sentence. (Hurford 2011: 278)

This casual impression is the basis for his meaning-based rule:

**Meaning-based:** To ask a question about something, signal the questioning intent with an appropriate auxiliary, then use an expression for the thing you are asking about. (This expression may or may not contain another auxiliary, but that doesn’t distract you.) (Hurford 2011: 279)

Hurford’s approach to semantics is highly referential and often reduces meaning to causal relations between words and objects. He talks about “a connection between hierarchical syntactic structure and the structure of the situations or events one is talking about” (p. 279).

On the empirical side, the proposal is almost vacuous. It accounts for none of the properties (i) to (iv) discussed above. It just stipulates that (i) Tense (‘auxiliary’) is involved, and says nothing about (ii) the Comp hierarchical position Tense occupies in questions. Concerning the fact that (iii) Tense must be from the main clause, the rule makes the vague stipulation that it involves the ‘appropriate auxiliary’, with a parenthesis to specifically exclude an auxiliary internal to the expression targeted by the question. However, this does not exclude all the other embedded auxiliaries as in (4b), (6c) or (9b). The fact that (iv) this construction correlates with a polar interrogative meaning is a total accident in this account. There is also no account of the fact that the ‘targeted expression’ happens to be the subject of the sentence (including ‘expletive’ *there* and *it*).

<sup>19</sup> This relation to simpler, more natural constructions to express quasi-logical properties is

Some linguists may feel that some positions, some syntactic relations, are natural, and that they tacitly interpret some elements in those positions. From the casual observation that, in some languages, some semantic relations between items are expressed by having these items occupy certain positions in a sentence, it is an easy step to assume that the mapping of semantic representations onto morphosyntax should be universally positional, i.e. that this is the ‘conceptually natural’ syntactic relation. But this idea faces the problem of accounting for all the cases in which languages use other means than linear juxtaposition to express relations, such as intonation, case marking, the use of loci in sign languages, etc. These conflicting facts force the adoption of a more complex model of grammar. For instance, case-marked elements typically have a relatively free ordering. This forces the adoption of costly constructs, such as assuming that Case-marked elements have a scrambling feature that induces pied-piping even after Case assignment, with the pied-piped element ‘attracted’ by a higher probe (Chomsky 2000). So Case-marking languages mysteriously happen to have extra mechanisms that conspire to give the impression of a freer order.<sup>20</sup> The positional view implicit in movement theory requires a stipulation barring these other coding possibilities from relating directly to semantics, and further stipulation of the additional mechanisms (such as the various kinds of features that trigger move), therefore facing a considerable empirical burden.

Returning to (26), *can* does not have to be in a lower position next to *eat* in order to bear on *eat* rather than *fly*. Consider a possible (simplified) structure for (26a):

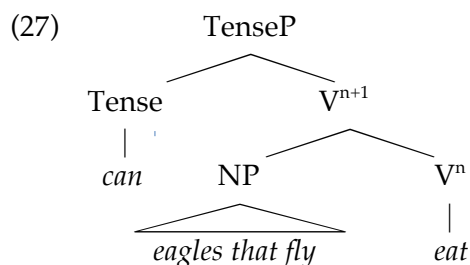

Since the modal is the sister of the verbal projection of *eat*, a simple rule of interpretation will have it apply to *eat* and not to *fly*.<sup>21</sup>

Another argument to assume that Tense moved in (1b) is based on the fact

---

assumed to be part of a more general behavioral strategy: A “hierarchical organization of behavior to meet some new situation may be constructed by transforming an organization previously developed in some familiar situation” (Miller & Chomsky 1963: 485).

<sup>20</sup> Proponents of Lexical Functional Grammar and Relational Grammar observed that this kind of approach does not provide a natural account of free order. Culicover & Jackendoff (2005: 190) remark that this theory “misses the traditional insight that linear order, case-marking, and agreement are independent grammatical devices that each can be used to link phonological structure to meaning; none of them is dependent on the others, but in some languages they may co-occur redundantly”.

<sup>21</sup> As shown in Bouchard (1984, 2002), this kind of analysis can be extended to long-distance dependencies as in *wh*-questions without the need of special rules of movement or devices such as the metavariables ( $\Uparrow$  and  $\Downarrow$ ) of Lexical Functional Grammar (Kaplan & Bresnan 1982) or SLASH propagation as in Generalized Phrase Structure Grammar (Gazdar 1982, Gazdar *et al.* 1985).

that the Tensed verb agrees with the subject as if this verb and the subject were in the same relation as in (1a). Hence, for a sentence like (28), Chomsky (2011: 272) assumes that there are heads “in the positions of the inflectional elements” and Berwick *et al* (2011: 1214) “indicate the actual position of interpretation with  $\mathbf{d}v$ , and the logically coherent but incorrect position by  $\mathbf{d}v^*$ ”.

(28) [do [eagles that  $\mathbf{d}v^*$  fly]  $\mathbf{d}v$  eat]

However, this positional view of agreement is not a fact. It presumes the result it aims for, namely that this agreement is dependent on a particular structural relation between the subject and Tense, and that this relation only holds in a structure corresponding to the declarative sentence. But the assumption that agreement depends on a structural relation faces empirical problems when there is agreement between a pronoun and its antecedent as in (29a), and even more when there are multiple antecedents as in (29b), or it occurs across sentences as in (29c), or in contexts of pragmatic anaphora as in (29d):

- (29) a. John<sub>i</sub> showed Mary a picture of *his*<sub>i</sub> / \**her*<sub>i</sub> uncle.  
 b. John<sub>i</sub> spoke to Mary<sub>j</sub> in the presence of Bill<sub>k</sub> and they<sub>i,j,k</sub> all agreed to leave.  
 c. John<sub>i</sub> came in. *He*<sub>i</sub> looked very happy.  
 d. A pointing to B who is trying to catch up with a woman who is skating very fast:  
 “You’ll never be able to catch up with *her*.”

To maintain that agreement in general depends on a particular kind of structural relation (like Spec–Head, for instance), very unlikely structures and operations will have to be postulated to account for these examples. Or else two theories of agreement will be required: a structure-based theory for subject–tense agreement, and another one for cases as in (28). However, a unified account of all types of agreement is possible, without excessive structural material: This is the approach to agreement proposed in Bouchard (1984, 1987, 1995: 225–226). Under this view, agreement is a consequence of interpretation, as expressed in (30) (see also Baker & Brame 1972, Jackendoff 1972, Fauconnier 1974, Lapointe 1980, Hoeksema 1983, Chierchia 1987, Pollard & Sag 1992).<sup>22</sup>

(30) *Coherence Condition on Coindexation*

Coindexed elements must be interpreted coherently.

The condition states that there can be no clash in the features of coindexed elements: Either the two elements have the same value for a feature, or one of them does not have the feature. Agreement follows from the Coherence Condition. In the case of subject–tense agreement, these elements are related in order to

<sup>22</sup> I define the condition in terms of coindexation because this is the most frequent means used to express the relation between two coreferential/agreeing elements. But this formalism is not crucial: It could be any other procedure with formally similar effects such as an arc in a general graph. The relation is of the type Saussure calls *rappports associatifs*, which are mediated by a paradigm and the link between the two terms is established *in absentia*.



mediate the relation between the ontologically different event and Tense, as mentioned above. This is what triggers agreement between subject and Tense (Bouchard 1995: 226–227). This agreement does not depend on a structural configuration, but is due to the lexical specifications that determine which actant of the event mediates the link between the event and a point in time, i.e. between the ISSUE and Tense.<sup>23</sup>

## 6. Conclusion: The UG Problem Solved

A learner exposed to the pair of sentences in (1) is not driven to choose between various movement rules because what is going on in polar interrogatives in English is not that words or phrases are moving around. Instead, deictic Tense is being combined from outside with the ISSUE-constituent. This relation is different from the one in declaratives and results in the illocutionary force of a polar interrogative. There is no reason why children would make errors as in (2c), (4b), (6c), (8c–d), (9b–c), or (11) by analogy, since this is not at all analogous to what they are doing. Children learn that a sentence is anchored deictically, they learn which of Tense or Person or Place is the deictic anchoring in their language, and they learn that this deictic anchoring can result in a declarative meaning. Children also learn how the deictic anchor is inserted with respect to the rest of a sentence to express that declarative meaning in their language, that is, they learn a sign — what form (*signifiant*) their language uses to express the declarative meaning (*signifié*). They also know that a different form corresponds to a different meaning: In the case at hand, they learn that a particular order of combination of the deictic anchor, or a marker on it such as *-tu* or *ni-*, or an intonation on the sentence, corresponds to a polar interrogative meaning. These are important aspects of the data provided by the interfaces. The Primary Linguistic Data is saturated with information germane to acquiring what is really going on in questions like (1b).

Given the actual richness of the PLD *about the relevant properties*, nativist speculations about a geno-typically specified UG are patently otiose. The canalization of language acquisition is not done by contingent UG constraints on the functioning of the formal apparatus, but is due to the substantial properties of the linguistic signs. “Infants somehow select language-related data from the ‘blooming buzzing confusion’ of the external world” (Berwick *et al.* 2011: 1208–1209). In particular, they learn signs, both unitary signs (morphemes, words) and

---

<sup>23</sup> Aissen (1989) discusses data that favor an account of agreement as a consequence of interpretation for Tense agreement. She gives examples from several languages where Tense does not agree with the subject, but rather with the combination of the subject and a comitative. Since phrases in two different, non-coordinated positions agree with Tense, there is no direct way to account for this kind of agreement in a structural analysis. On the other hand, if agreement is a consequence of interpretation, one simply has to assume that the index of both the subject and the comitative determine verbal agreement in these languages, as in other cases of multiple antecedents such as (20b).

The analysis of agreement as a consequence of the Coherence Condition also gets support from sylleptic agreement (agreement based on meaning instead of form), to which it extends naturally, as shown in Bouchard (1995: sect. 3.3.2.4).

combinatorial signs (forms such as juxtaposition in a particular order or markings on heads or dependents, or particular intonations, all of which can be linked to particular meanings such as argumenthood, adjuncthood, polar interrogative; see Bouchard 1996, 2002). This is the logical minimum: it is necessary, and sufficient to generalize from the data they are exposed to.

Question formation in English is a meaning-dependent insertion of Tense in a particular position, and not the result of a syntactic operation moving things around. This is revealed by the fact that a POS argument based on movement rules in these sentences fails in the wildest cases, even when it is backed by structure dependence and several other constraints attributed to UG. That procedure can pair sounds with more interpretations than competent speakers permit, as well as pair the polar interrogative interpretation with more sounds than competent speakers permit. Structure dependence is noise in the experiment due to a faulty experimental method, chiefly, the assumption of natural positions of interpretation and movement. The noise is so intense that its users fail to see that the method does not account for even the wildest cases, and they fail to discuss why those combinations of forms are attributed the meaning of polar interrogative. This is similar to a situation where someone would discuss the pair of sentences *John saw Mary* and *Mary saw John* without mentioning how the difference in the way the words combine corresponds to a difference in interpretation. They ignore this most elementary property of the sentences and just try to describe what goes where linearly and hierarchically. Some 50-plus years after examples like (1) were initially offered, why Tense ends up in Comp remains a total mystery in this approach.

Transformationalists think about question formation as potentially linear as in the errors in (2c), (4b), (6c), (8c–d), (9b–c), or (11) because the vision of their theory allows it: Linear systems are part of the set of possible formal systems among which they are trying to find the subset that generates human languages. So it is one option that they must rule out by a language-specific constraint in UG, like structure dependence. But errors as in (2c), (4b), (6c), (8c–d), (9b–c), or (11) are actually ruled out by a principled reason: In these ungrammatical cases, either there is no sign like a special order changing the relation of Tense with the ISSUE, or no particle marking the sentence with semantics relevant to polar interrogatives, or the semantics resulting from the combination of the elements in that order is uninterpretable.

Over the years, there has been a lot of swapping of one theoretical device for another with similar effects, for example, from a rule that explicitly moves AUX across the subject to a feature that attracts the tensed V to Comp, from cycles to phases, and so on. These shuffles do not improve overall UG stipulations. Hauser *et al.* (2002) propose a divide between the faculty of language in the broad sense (FLB) and in the narrow sense (FLN) in an attempt to reduce the content of UG (i.e. FLN). Many mechanisms of FLB are present among non-human animals, and in non-linguistic activities in humans. “That is not the case, though, of FLN, which is something like a residue of the uniquely human nature of the language faculty, which, by definition, cannot be compared to anything existing in the mind of other species (nor even in other domains of the human mind)” (Boeckx & Longa 2011: 265). If this residue UG/FLN was extremely

limited, we would be approaching the ‘strong minimalist hypothesis’. However, despite the expressed intent to eliminate UG — this repertoire of the unexplained elements of  $S_0$ , current generative models still appeal to several of these elements in their actual analyses. Here is an illustrative sample taken mostly from Hornstein & Boeckx (2009) and Narita & Fujita (2010):

- constituency;
- endocentricity labeling;
- c-command;
- functional categories that proliferate in cartography;
- parameters (intractable number of micro or macro) distributed over different modules of FL;
- bind and binding conditions;
- displacement;
- uninterpretable features and specifications about which elements they may attach to and when;
- agreement;
- cycle/phase bounding nodes;
- Phase Impenetrability;
- Transfer;
- locality conditions (Ross’s Problem: why does locality hold for move but not pronominalization?)
- condition on theta assignment: arguments must be initially merged in theta-positions;
- Numeration: once a NUM is exhausted, a new NUM can be selected to extend it cyclically (Uriagereka (2002: 7);
- Linearize: there has to be a procedure *Linearize*, with something like the LCA to constrain it.

The goal of eliminating the unexplained elements listed in UG will remain a very unfinished business as long as the emphasis is on computational tools and the facts are seen as resulting from the application of these tools. Because it still constantly resorts to dumping unexplained elements into UG, generative grammar uningenuously exposes the inadequacy of many of its claimed explanations of linguistic facts.

Given the epistemological problems that the concept of UG raises, there should be very strong empirical reasons to resort to it. One main source is the logical problem of language acquisition. But Plato’s problem is not insurmountable in the case of language. We know so much because the evidence we have is very informative about signs and how they combine. Contra Fodor (2001), children do not need a dedicated Learning Machine like UG to figure out what grammar/syntax underlies the language they are exposed to: Whatever Learning Machine enables them to learn signs also enables them to learn combinatorial signs such as dedicated orders of signs.

Foregoing UG does not mean that every possible option is admitted and that languages can vary infinitely. There are factors other than language-specific UG conditions that canalize grammar very stringently. Language being a system that links concepts and percepts, it is shaped by constraints from the CI and SM systems that predate it and thus are not specific to it. In any model, the logically prior properties of the perceptual and conceptual systems necessarily impose boundaries within which a child charts a highly circumscribed course in language development. I make the parsimonious hypothesis that these properties are sufficient and are the only canalization elements of language. We have seen how this works in circumscribing question formation: this kind of system covers the full range of examples just discussed, adequately capturing what knowledge speakers acquire, while minimizing any posited language-specific innate endowment. SM and CI factors also account for the restrictions on other well-known constructions that have been used to argue for POS and UG. See for instance the account of classical islands in Bouchard (1984, 2002: 348–358), as well as the seminal work of Erteschik-Shir (1973), and the scopal analysis in Szabolcsi & den Dikken (1999) and Szabolcsi (2002); the account of binding conditions suggested in Bouchard (2006) and developed in Bouchard (in progress); the way the meaning of Negative Polarity Items accounts for the restrictions on their distribution without appealing to UG constraints, as shown in Giannakidou (2001).

## References

- Adger, David. 2003. *Core Syntax*. Oxford: Oxford University Press.
- Aissen, Judith. 1989. Agreement controllers and Tzotzil comitatives. *Language* 65, 518–536.
- Baker, Carl. 1970. Notes on the description of English questions: The role of an Abstract question morpheme. *Foundations of Language* 6, 179–219.
- Baker, Carl, and Brame, Michael. 1972. Global rules: A rejoinder. *Language* 48, 51–77.
- Berwick, Robert & Noam Chomsky. 2008. 'Poverty of the Stimulus' revisited: Recent Challenges Reconsidered. Ms. Cambridge, MA.
- Berwick, Robert, Paul Pietroski, Beracah Yankama & Noam Chomsky. 2011. Poverty of the Stimulus revisited. *Cognitive Science* 35, 1207–1242.
- Bishop, Dorothy. 2009. What can developmental language impairment tell us about genetic bases of syntax?. In Derek Bickerton & Eörs Szathmáry (eds.), *Biological Foundations and Origin of Syntax*, 185–204. Cambridge, MA: MIT Press.
- Boeckx, Cedric & Víctor M. Longa. 2011. Lenneberg's views on language development and evolution and their relevance for modern biolinguistics. *Biolinguistics* 5, 254–273.
- Bolender, John, Burak Erdeniz & Cemil Kerimoglu. 2008. Human uniqueness, cognition by description, and procedural memory. *Biolinguistics* 2, 129–151.
- Bouchard, Denis. 1979. Conjectures sur une grammaire indépendante du contexte

- pour les langues naturelles. Montreal: Université de Montréal M.A. thesis.
- Bouchard, Denis. 1982. On the content of empty categories. Cambridge, MA: MIT Ph.D. dissertation.
- Bouchard, Denis. 1984. *On the Content of Empty Categories*. Dordrecht: Foris.
- Bouchard, Denis. 1987. A few remarks on past participle agreement. *Linguistics and Philosophy* 10, 449–474.
- Bouchard, Denis. 1991. From conceptual structure to syntactic structure. In Kathy Leffel & Denis Bouchard (eds.), *Views on Phrase Structure*, 21–35. Dordrecht: Kluwer.
- Bouchard, Denis. 1995. *The Semantics of Syntax*. Chicago, IL: University of Chicago Press.
- Bouchard, Denis. 1996. Sign languages and language universals: The status of order and position in grammar. *Sign Language Studies* 91: 101–160.
- Bouchard, Denis. 1998. The syntax of sentential negation in French and English. In Danielle Forget, Paul Hirschbühler, France Martineau & Maria-Luisa Rivero (eds.), *Negation and Polarity: Syntax and Semantics*, 29–52. Amsterdam: John Benjamins.
- Bouchard, Denis. 2002. *Adjectives, Number and Interfaces: Why Languages Vary*. Oxford: Elsevier Science.
- Bouchard, Denis. 2006. Simply disappointing: A response to Crain & Pietroski. *Lingua* 116, 69–77.
- Bouchard, Denis. 2011. Review of Guglielmo Cinque, *The Syntax of Adjectives: A Comparative Study*. *Linguist List* 22, 2513. [<http://linguistlist.org/issues/22/22-2513.html>]
- Bouchard, Denis. In progress. *The Nature and Origin of Language*. Montreal: Université de Québec à Montréal.
- Bouchard, Denis & Colette Dubuisson. 1995. Grammar, Order and Position of WH-signs in Quebec Sign Language. *Sign Language Studies* 87, 99–139.
- Bouquet, Simon & Rudolf Engler. 2002. *Écrits de Linguistique Générale par Ferdinand de Saussure*. Paris: Gallimard.
- Cheng, Lisa Lai-Shen & Johan Rooryck. 2000. Licensing wh-in-situ. *Syntax* 3, 1–19.
- Chierchia, Gennaro. 1987. Aspects of a categorial theory of binding. In Richard Oehrle, Emmon Bach & Daniel Wheeler (eds.), *Categorial Grammars and Natural Language Structures*, 125–151. Dordrecht: Reidel.
- Chomsky, Noam. 1957. *Syntactic Structures*. The Hague: Mouton.
- Chomsky, Noam. 1965. *Aspects of the Theory of Syntax*. Cambridge, MA: MIT Press.
- Chomsky, Noam. 1968. *Language and Mind*. New York: Harcourt, Brace, Jovanovitch.
- Chomsky, Noam. 1971. *Problems of Knowledge and Freedom*. London: Fontana.
- Chomsky, Noam. 1973. Conditions on Transformations. In Stephen Anderson & Paul Kiparsky (eds.), *A Festschrift for Morris Halle*, 232–286. New York: Holt, Rinehart & Wilson.
- Chomsky, Noam. 1981. *Lectures on Government and Binding*. Dordrecht: Foris Publications.
- Chomsky, Noam. 1995. *The Minimalist Program*. Cambridge, MA: MIT Press.

- Chomsky, Noam. 2000. Minimalist inquiries: The framework. In Roger Martin, David Michaels & Juan Uriagereka (eds.), *Step by Step: Essays on Minimalist Syntax in Honor of Howard Lasnik*, 89–115. Cambridge, MA: MIT Press.
- Chomsky, Noam. 2005. Three factors in language design. *Linguistic Inquiry* 36, 1–22.
- Chomsky, Noam. 2007a. Of Minds and Language. *Biolinguistics* 1, 9–27.
- Chomsky, Noam. 2007b. Approaching UG from below. In Uli Sauerland & Hans-Martin Gärtner (eds.), *Interfaces + Recursion = Language? Chomsky's Minimalism and the View from Syntax-Semantics* (Studies in Generative Grammar 89), 1–29. Berlin: Mouton de Gruyter.
- Chomsky, Noam. 2010a. Poverty of stimulus: Unfinished business. Transcription of oral presentation (Johannes-Gutenberg University Mainz, March 24, 2010).
- Chomsky, Noam. 2010b. Poverty of stimulus: Unfinished business. Oral presentation (Université Pierre et Marie Curie, Paris, May 29, 2010). <http://www.chomsky.fr>
- Chomsky, Noam. 2011. Language and other cognitive systems. What is special about language? *Language Learning and Development* 7, 263–278.
- Cinque, Guglielmo. 1994. On the Evidence for Partial N Movement in the Romance DP. In Guglielmo Cinque, Jan Koster, Jean-Yves Pollock, Luigi Rizzi & Raffaella Zanuttini (eds.), *Paths Towards Universal Grammar*, 85–110. Georgetown: Georgetown University Press.
- Cinque, Guglielmo. 1999. *Adverbs and Functional Heads*. Oxford: Oxford University Press.
- Cinque, Guglielmo. 2002. *The structure of DP and IP: The Cartography of Syntactic Structures*. Oxford: Oxford University Press.
- Cinque, Guglielmo. 2010. *The Syntax of Adjectives: A Comparative Study*. Cambridge: MIT Press.
- Crain, Stephen. 1991. Language acquisition in the absence of experience. *Behavioral and Brain Sciences* 14, 597–650.
- Crain, Stephen & Paul Pietroski. 2006. Is Generative Grammar deceptively simple or simply deceptive. *Lingua* 116, 64–68.
- Culicover, Peter & Ray Jackendoff. 2005. *Simpler Syntax*. Oxford: Oxford University Press.
- Di Sciullo, Anna Maria & Daniela Isac. 2008. The asymmetry of merge. *Biolinguistics* 2, 260–290.
- Emonds, Joseph. 1978. The verbal complex V'-V in French. *Linguistic Inquiry* 9, 151–175.
- Erteschik-Shir, Nomi. 1973. *On the Nature of Island Constraints*. Ph.D. dissertation, MIT.
- Fauconnier, Gilles. 1974. *La Coréférence: Syntaxe ou Sémantique*. Paris: Éditions du Seuil.
- Fodor, Jerry. 2001. Doing without what's within: Fiona Cowie's critique of nativism. *Mind* 110, 99–148.
- Gazdar, Gerald. 1982. Phrase structure grammar. In Pauline Jacobson & Geoffrey K. Pullum (eds.), *The Nature of Syntactic Representation*, 131–186. Dordrecht: Reidel.

- Gazdar, Gerald, Ewan Klein, Geoffrey K. Pullum & Ivan Sag. 1985. *Generalized Phrase Structure Grammar*. Oxford: Blackwell.
- Giannakidou, Anastasia. 2001. The Meaning of free choice. *Linguistics and Philosophy* 24, 659–735.
- Goldsmith, John. 1981. Complementizers and root sentences. *Linguistic Inquiry* 12, 541–574.
- Grimshaw, Jane. 1979. Complement selection and the lexicon. *Linguistic Inquiry* 10, 279–326.
- Hauser, Marc D., Noam Chomsky & W. Tecumseh Fitch. 2002. The faculty of language: What is it, who has it, and how did it evolve? *Science* 298, 1569–1579.
- Henry, Alison. 1995. *Belfast English and Standard English. Dialect Variation and Parameter Setting*. Oxford: Oxford University Press.
- Hoeksema, Jack. 1983. Plurality and conjunction. In Alice ter Meulen (ed.), *Studies in Model Theoretic Semantics*, 63–83. Dordrecht: Reidel.
- Holmberg, Anders. 2000. OV order in Finnish. In Peter Svenonius (ed.), *The Derivation of VO and OV*, 123–152. Amsterdam: John Benjamins.
- Hornstein, Norbert & Cedric Boeckx. 2009. Approaching universals from below: I-universals in light of a minimalist program for linguistic theory. In Morten Christiansen, Christopher Collins & Shimon Edelman (eds.), *Language Universals*, 79–98. Oxford: Oxford University Press.
- Hurford, James. 2011. *The Origins of Grammar*. Oxford: Oxford University Press.
- Jackendoff, Ray. 1972. *Semantic Interpretation in Generative Grammar*. Cambridge, MA: MIT Press.
- Johnson, David & Shalom Lappin. 1999. *Local Constraints vs Economy*. Stanford: Center for the Study of Language and Information.
- Kaplan, Ronald M. & Joan Bresnan. 1982. Lexical-Functional Grammar: A formal system for grammatical representation. In Joan Bresnan (ed.), *The Mental Representation of Grammatical Relations*, 173–281. Cambridge, MA: MIT Press.
- Kayne, Richard. 1994. *The Antisymmetry of Syntax*. Cambridge, MA: MIT Press.
- Kayne, Richard. 2002. On some prepositions that look DP-internal: English *of* and French *de\**. *Catalan Journal of Linguistics* 1, 71–116.
- Kayne, Richard. 2008. Expletives, datives, and the tension between morphology and syntax. In Theresa Biberauer (ed.), *The Limits of Syntactic Variation*, 175–217. Philadelphia: John Benjamins.
- Kegl, Judy, Carol Neidle, Dawn MacLaughlin, Jack Hoza & Benjamin Bahan. 1996. The case for grammar, order and position in ASL: A reply to Bouchard and Dubuisson. *Sign Language Studies* 90, 1–23.
- Koster, Jan. 2009. Ceaseless, unpredictable creativity: Language as technology. *Biolinguistics* 3, 61–92.
- Ladusaw, William. 1996. Negative concord and ‘mode of judgement’. In Heinrich Wansing (ed.), *Negation: A Notion in Focus*, 127–143. Berlin: Walter de Gruyter.
- Lakatos, Imre. 1970. Falsification and the methodology of scientific research programmes. In Imre Lakatos & Alan Musgrave (eds.), *Criticism and the Growth of Knowledge*, 91–196. Cambridge: Cambridge University Press.

- Lapointe, Steve. 1980. A theory of grammatical agreement. Amherst, MA: University of Massachusetts dissertation.
- Matthews, P. H. 1993. *Grammatical Theory in the United States from Bloomfield to Chomsky*. Cambridge: Cambridge University Press.
- May, Robert. 1985. *Logical Form: Its Structure and Derivation*. Cambridge, MA: MIT Press.
- Narita, Hiroki & Koji Fujita. 2010. A Naturalist Reconstruction of Minimalist and Evolutionary Biolinguistics. *Biolinguistics* 4, 356–376.
- Perfors, Amy, Josh Tenenbaum & Terry Regier. 2011. Poverty of the stimulus: A rational approach. *Cognition* 118, 306–338.
- Pesetsky, David. 1982. Paths and categories. Cambridge, MA: MIT dissertation.
- Piattelli-Palmarini, Massimo & Juan Uriagereka. 2004. The immune syntax: The evolution of the language virus. In Lyle Jenkins (ed.), *Variations and Universals in Biolinguistics*, 341–377. Amsterdam: Elsevier.
- Pinker, Steven. 1994. *The Language Instinct*. New York: William Morrow and Company.
- Pollard, Carl & Ivan Sag. 1992. Anaphors in English and the Scope of Binding Theory. *Linguistic Inquiry* 23, 261–303.
- Pollock, Jean-Yves. 1989. Verb movement, Universal Grammar, and the structure of IP. *Linguistic Inquiry* 20, 365–424.
- Regier, Terry. 1996. *The Human Semantic Potential: Spatial Language and Constrained Connectionism: Neural Network Modeling and Connectionism*. Cambridge, MA: MIT Press.
- Ritter, Elizabeth & Martina Wiltschko. 2009. Varieties of INFL: TENSE, LOCATION, and PERSON. In Hans Broekhuis, Jeroen van Craenenbroeck & Henk van Riemsdijk (eds.), *Alternatives to Cartography*, 153–201. Berlin: Mouton de Gruyter.
- Rivero, Maria-Luisa. 1994. Clause Structure and V-movement in the Languages of the Balkans. *Natural Language and Linguistic Theory* 12, 63–120.
- Rizzi, Luigi. 1990. *Relativized Minimality*. Cambridge, MA: MIT Press.
- de Saussure, Ferdinand. 1916. *Cours de Linguistique Générale*. Paris: Payot.
- Schoeneman, Peter. 2005. Conceptual complexity and the brain: understanding language origins. In James W. Minett & William S.-Y. Wang (eds.), *Language Acquisition, Change and Emergence: Essays in Evolutionary Linguistics*, 1–48. Kowloon: City University of Hong Kong Press.
- Slobin, Dan. 1975. On the nature of talk to children. In Eric Lenneberg & Elizabeth Lenneberg (eds.), *Foundations of Language Development*, 283–297. New York: Academic Press.
- Sportiche, Dominique. 1995. Sketch of a reductionist approach to syntactic variations and dependencies. In Hector Campos & Paula Kempchinsky (eds.), *Evolution and Revolution in Romance Syntax*, 356–398. Georgetown: Georgetown University Press.
- Svenonius, Peter. 1994. C-selection as feature checking. *Studia Linguistica* 48, 133–155.
- Szabolcsi, Anna. 2002. Strong vs weak islands. In *The Syntax Companion*. [[https://files.nyu.edu/as109/public/szabolcsi\\_strong\\_and\\_weak\\_islands.htm](https://files.nyu.edu/as109/public/szabolcsi_strong_and_weak_islands.htm)]



- Szabolcsi, Anna & Marcel den Dikken. 1999. Islands. *Glott International* 4, 3–8.
- Tesnière, Lucien. 1959. *Éléments de syntaxe structurale*. Paris: Editions Klincksieck.
- Uriagereka, Juan. 2002. *Derivations*. London: Routledge.
- Vaissière, Jacqueline. 1995. Phonetic explanations for cross-linguistic prosodic similarities. *Phonetica* 52, 123–130.
- Wasow, Thomas. 1979. *Anaphora in Generative Grammar*. Gent: E. Story-Scientia.

*Denis Bouchard*  
*Université de Québec à Montréal*  
*Department of Linguistics*  
*P.O. Box 8888, Downtown Station*  
*Montréal, QC H3C 3P8*  
*Canada*  
[bouchard.denis@uqam.ca](mailto:bouchard.denis@uqam.ca)

# English-Speaking Children's Interpretation of Disjunction in the Scope of 'not every'

Anna Notley, Rosalind Thornton & Stephen Crain

This study examined 4- to 5-year-old English-speaking children's interpretations of sentences containing negation, the universal quantifier, and disjunction. Disjunction is assigned two different meanings in such sentences depending on its position in surface syntax: in the subject phrase of 'not every' (e.g., *not every passenger who ordered chicken or beef became ill*), a disjunctive meaning is assigned to disjunction (e.g. at least one passenger who ordered chicken OR at least one passenger who ordered beef became ill); in the predicate phrase of 'not every' (e.g., *not every passenger who became ill ordered chicken or beef*), a conjunctive meaning is assigned (e.g., at least one passenger who became ill did not order chicken AND did not order beef). If children bring knowledge of combinatory logical principles to the task of language acquisition, then they should be sensitive to this asymmetry. We tested this prediction using a truth-value judgment task.

*Keywords:* acquisition of semantics; disjunction in natural language; scope ambiguity

## 1. Introduction

This paper explores how 4- to 5-year-old English-speaking children interpret sentences that contain three logical expressions: negation, the universal quantifier, and disjunction. It is instructive to look at how children interpret complex sentences like these, because it is unlikely that they have encountered many (or any) such sentences in the primary linguistic data. Therefore, the interpretations children assign to such sentences may be revealing about their innate knowledge of combinatory principles of logic. In the previous literature, children's understanding of sentences with the universal quantifier and disjunction has been studied, but without negation. Let us begin by reviewing that literature, focusing on sentences without negation such as (1) and (2). Then we can

---

This work was supported by the Australian Research Council Centre of Excellence in Cognition and its Disorders (CE110001021) <http://www.ccd.edu.au>, and by an Australian Research Council Discovery Grant (DP0879842). We wish to acknowledge the valuable input of Drew Khlentzos and Peng Zhou, as well as of the anonymous reviewers. Finally, we thank the administrators, teachers and children at Gumnut Cottage and at Banksia Cottage on the campus of Macquarie University for making this study so enjoyable.



appreciate the consequences of introducing negation for semantic interpretation.

When disjunction appears in the subject phrase of a universally quantified sentence, as in (1a), it generates a conjunctive interpretation, as indicated in (1b). However, when disjunction appears in the predicate phrase, as in (2a), it licenses disjunctive truth conditions, as indicated in (2b).

- (1) Every passenger who ordered chicken or beef became ill.
- a. Every <sub>SUBJ</sub>[passenger who ordered chicken OR beef] <sub>PRED</sub>[became ill].
  - b. Meaning: every passenger who ordered chicken became ill AND every passenger who ordered beef became ill (AND every passenger who ordered both became ill).
- (2) Every passenger who became ill ordered chicken or beef.
- a. Every <sub>SUBJ</sub>[passenger who became ill] <sub>PRED</sub>[ordered chicken OR beef].
  - b. Meaning: every passenger who became ill ordered chicken OR beef (OR possibly both).

As these examples illustrate, there is an asymmetry in the interpretation of disjunction in (1) and (2) depending on the surface structure position of the disjunction word (in the subject phrase versus the predicate phrase). The asymmetry arises, first, because disjunction is assigned the truth conditions associated with inclusive-*or*, as in classical logic and, second, because the entailment relations of the subject phrase and the predicate phrase of the universal quantifier are reversed. Briefly, the subject phrase is downward entailing (licensing inferences from sets to their subsets), so disjunction is assigned a conjunctive interpretation when it appears in the subject phrase. By contrast, the predicate phrase of the universal quantifier is not downward entailing, so disjunction is assigned 'disjunctive' truth conditions, rather than a conjunctive interpretation, when it appears in the predicate phrase. A more detailed explanation of this asymmetry is given in section 1.1.

The previous literature on children's acquisition of logical principles has emphasized the difficulty children would experience if they had to learn the meanings of logical expressions based on the input from adults (Crain *et al.* 2006, Crain *et al.* 2005, Crain & Khlentzos 2008, 2010, Crain & Thornton 2006). First consider, for example, how English-speaking children learn that 'or' is inclusive-*or*, and not exclusive-*or*. This is problematic because 'or' is far more likely to appear in linguistic contexts that invite an exclusive-*or* interpretation, rather than an inclusive-*or* interpretation, in the spontaneous speech of both children and adults (Morris 2008). In a review of 240 transcriptions of audio-taped exchanges between 2- to 5-year-old children and their parents taken from the CHILDES database, Morris (2008) reports 465 uses of 'or' out of a total of 100,626 conversational turns. For children, utterances in which disjunction meant inclusive-*or* were produced less than 10% of the time, and uses of 'or' with an inclusive-*or* interpretation were produced by adults only slightly more often than 10% of the time. A representative sample of input to Adam and Eve from the Brown corpus (Brown 1973) is provided in Crain *et al.* (2005), further illustrating the predominance of the exclusive-*or* interpretation of disjunction in the input to children.

Further arguments against a learning account are based on the asymmetry in the truth conditions associated with disjunction when it appears in the subject phrase versus the predicate phrase of the universal quantifier. The universal quantifier is special in this regard. Other determiner phrases such as *some Ns* and *no Ns* assign the same truth conditions to disjunction when it appears in either argument. Disjunction is assigned a conjunctive interpretation in both arguments of *no Ns*, and disjunction is assigned disjunctive truth conditions in both arguments of *some Ns*. These determiner phrases, therefore, fail to support any substantive generalizations about the asymmetry in the interpretation of disjunction in sentences with the universal quantifier.

Worse still for a learning account is the fact that the input contains little, if any, information about how the universal quantifier and disjunction are interpreted when they appear together. We surveyed every adult utterance in the MacWhinney and Brown corpora in the CHILDES database; a total of 130,337 utterances (Brown 1973, MacWhinney 2000). There were just two instances of disjunction in the predicate phrase of 'every', and there were no cases in which disjunction appeared in the subject phrase of sentences with 'every' (neither did disjunction occur in the subject phrase of sentences with 'all'). Despite the paucity of evidence, previous research on child language has found that pre-school children know the asymmetry in the interpretation of disjunction in sentences like (1) and (2). In both English and in Mandarin Chinese, children have been shown to generate the conjunctive interpretation of disjunction in sentences like (1), but not in ones like (2) (Boster & Crain 1993, Chierchia *et al.* 2001, Chierchia *et al.* 2004, Gualmini *et al.* 2003, Su & Crain 2009).

To recap, children have been found to know the asymmetry in the interpretation of disjunction in the subject phrase versus the predicate phrase of the universal quantifier. This difference in interpretation hinges on two facts; first, that disjunction is inclusive-*or* and, second, that the universal quantifier (unlike some other quantifiers) interacts differently with (inclusive) disjunction when it appears in the subject phrase versus the predicate phrase. Yet, children have little direct experience bearing on either of these facts. The majority of their input is consistent with disjunction being exclusive-*or*, and children rarely encounter sentences that contain both disjunction and the universal quantifier.

Taken together, these observations about the input children receive, and about what children know about the meanings of complex sentences, seem inconsistent with a learning account of children's knowledge of logical principles. The alternative is to suppose that children are innately endowed with knowledge of the relevant combinatory principles of logic. Further support for this innateness hypothesis is the finding that children even know the asymmetry between the two arguments of 'every' in sentences with the existential quantifier 'some' and negation. This aspect of children's knowledge of logical principles is particularly striking as this phenomenon involves three logical operators, as the sentences in (3) and (4) illustrate.

- (3) Every farmer who didn't clean some animal has a broom.
- a. Every <sub>SUBJ</sub>[farmer who did NOT clean SOME animal] <sub>PRED</sub>[has a broom].
  - b. Every farmer who didn't clean any animal has a broom. (not > some)

- (4) Every farmer didn't clean some animal.
- a. Every <sub>SUBJ</sub>[farmer] <sub>PRED</sub>[did NOT clean SOME animal].
  - b. For every farmer, there is some animal that he did not clean.  
(some > not)

When negation and 'some' occur together in the subject phrase of a universally quantified sentence, as in (3a), negation takes scope over 'some', as indicated in (3b). We understand the sentence to mean that farmers who didn't clean any animals at all have brooms. On the other hand, when negation and 'some' occur together in the predicate phrase, as in (4a), 'some' is assigned wide scope over negation, as indicated in (4b). We understand the sentence to mean that every farmer did not clean at least one animal (although they probably cleaned some other animals). Gualmini (2005) tested 30 3- to 5-year-old English-speaking children on sentences like these, and found that the child subjects correctly assigned opposing scope relations to negation and 'some' in these two linguistic environments.

Previous results have shown, therefore, that children are aware of the consequences of the asymmetry between the two arguments of the universal quantifier, and are able to demonstrate this knowledge even in sentences with three logical operators; sentences that they are unlikely to have ever come across. The present study was designed to take this important finding a step further. The study asks whether children are aware of the reversal of this asymmetry under negation.

Negation reverses entailment relations. Consider the interpretive consequences of adding negation to sentences (1) and (2). The results are sentences (5) and (6). While disjunction appears in the subject phrase of (5), it no longer generates a conjunctive interpretation, due to negation. However, disjunction now generates a conjunctive interpretation when it appears in the predicate phrase, as in (6).

- (5) Not every passenger who ordered chicken or beef became ill.
- a. Not every <sub>SUBJ</sub>[passenger who ordered chicken OR beef] <sub>PRED</sub>[became ill].
  - b. Meaning: at least one passenger who ordered chicken OR beef was unaffected.
- (6) Not every passenger who became ill ordered chicken or beef.
- a. Not every <sub>SUBJ</sub>[passenger who became ill] <sub>PRED</sub>[ordered chicken OR beef].
  - b. Meaning: at least one passenger who became ill did not order chicken AND did not order beef.

In short, there is an asymmetry in the interpretation of disjunction in (5) and (6), depending on the surface structure position of disjunction (whether it appears in the subject phrase versus the predicate phrase). However, the asymmetry is the reverse of that observed in examples (1) and (2). If it turns out that children know the asymmetry in the interpretation of disjunction in sentences like (5) and (6), as well as the reverse asymmetry in sentences like (1) and (2), then this will

constitute additional evidence that knowledge about combinatory principles of logic is available to children from the earliest stages of language acquisition. A learning account of these particular phenomena is highly problematic. We surveyed the MacWhinney and Brown corpora on the CHILDES database and found no instances of the compound quantifier 'not every'. There were 40 adult utterances in which 'not' preceded the quantifier 'all', but none of them also included the disjunction operator.

The present study has another research aim. While we were conducting this study, we came across an unanticipated finding. It turned out that the adult English-speakers we interviewed judged sentences like (6) to be ambiguous. We repeat example (6), as (7) below, to illustrate the two adult interpretations.

- (7) Not every passenger who became ill ordered chicken or beef.
- a. Meaning 1: At least one passenger who became ill did not order chicken AND did not order beef.
  - b. Meaning 2: It was chicken or beef that not every passenger who became ill ordered (at least one passenger who became ill did not order chicken, OR did not order beef, OR did not order either meat).

On the reading indicated in 7(a), disjunction is interpreted within the scope of 'not every', so the meaning can be paraphrased as follows: 'There is at least one sick passenger who did not eat chicken AND who did not eat beef'. This is the conjunctive interpretation of disjunction. On the reading indicated in 7(b), by contrast, disjunction is interpreted as taking wider scope than 'not every', so the meaning can be paraphrased as follows: 'It was chicken OR beef that not every passenger who became ill ordered'. In other words, the sentence is true if either (a) some sick passenger did not eat chicken (but did eat beef), or (b) some sick passenger did not eat beef (but did eat chicken), or if some sick passenger did not eat either dish. This is the disjunctive interpretation. Although the disjunctive interpretation is not the preferred reading for adult speakers of English, we discovered in the course of our study that it is available to many adult speakers. Given that two readings are possible for sentences like (7), children too must be faced with this ambiguity. This means that we also need to address the question of which of these two readings constitutes children's initial hypothesis.

In answering this question, we began with the observation that one of the readings of (7), 7(a), asymmetrically entails the other reading, 7(b). That is, (7) is true on the meaning represented in 7(a) in just one circumstance. The same circumstance makes sentence (7) true when it is assigned the meaning in 7(b), but there are other circumstances that also make (7) true on the meaning represented in 7(b). Simply put, 7(a) is the subset reading, and 7(b) is the superset reading. This phenomenon is a semantic version of the familiar subset problem described by Berwick (1985) and by Pinker (1984). Both of these researchers observed that a learnability problem could arise for children when one language generates a subset of the sentences generated by another language. In the absence of negative evidence, children are compelled to initially adopt the 'subset' language.

Since the early 1990's, it has been claimed, albeit controversially, that when children are presented with a semantic ambiguity of the kind in (7), that they are

also guided by a learnability constraint that compels them to initially adopt the subset interpretation (7a) in order to guarantee that the superset reading (7b) can be learned from positive evidence, if the superset interpretation is assigned by adult speakers of the local language (Crain *et al.* 1994). This constraint on semantic interpretation was initially called the Semantic Subset Principle, to distinguish it from the (syntactic) Subset Principle proposed originally by Berwick and by Pinker, but it has recently been reformulated as the Semantic Subset Maxim in order to handle cases of scope ambiguity (Notley *et al.* 2011). According to the Semantic Subset Maxim, children should initially prefer the scope assignment that generates the conjunctive interpretation 7(a). The present study is designed to test this prediction.

To sum up, the present study has two goals. The first goal is to determine whether children are aware of the asymmetry in the interpretation of disjunction in the two arguments of the complex quantifier 'not every'. If so, children should assign a disjunctive interpretation to disjunction in the first argument, the subject phrase, and children should assign a conjunctive interpretation to disjunction in the second argument, the predicate phrase. To arrive at these two different interpretations of disjunction, children must apply intricate combinatory principles of logic, based on the meanings of logical expressions. Our first goal, then, is to determine the extent to which (first-order) logic determines both the underlying semantics of various logical operators and whether logic dictates how the meanings of these logical operators are combined for children. We have documented that these principles are not amply demonstrated in the input. Therefore, if children successfully process the interpretations of complex sentences with multiple logical operators, this can be taken as evidence that they have innate knowledge of the combinatory principles of (first order) logic. Moreover, this evidence will extend current findings to a complex quantifier that is subject to a logical equivalence rule not yet investigated in the literature. The second goal of the study is to test the predictions of the Semantic Subset Maxim concerning children's initial hypotheses when they are presented with certain kinds of semantic scope ambiguities.

The paper is organized as follows. First, we will present the logical principles that are responsible for the conjunctive interpretation of disjunction in certain contexts, as opposed to the disjunctive interpretation. For each principle we will also review some relevant child acquisition data supporting the view that the principle is innately specified, rather than learned. This background will then allow us to understand what logical knowledge children need in order to compute the conjunctive interpretation of disjunction in the predicate phrase, but not in the subject phrase of the compound quantifier 'not every'. We will then introduce the rationale behind the Semantic Subset Maxim and review some current support for this maxim. Finally, we will outline how our study further tests both the Semantic Subset Maxim, and the logical principles that are at play when children comprehend sentences that contain 'not every' and disjunction.

### *1.1. The Source of the Conjunctive Interpretation of Disjunction*

A conjunctive interpretation of disjunction arises when disjunction is interpreted

in the scope of a downward entailing (DE) operator. To access this interpretation children must know the underlying meaning of disjunction, and they must know which expressions in natural language are downward entailing. These two logical facts are outlined below, along with what research studies have determined to date about children's sensitivity to each of these facts.

### 1.1.1. Logical Fact 1: OR in Natural Language is Inclusive-Or

The first logical fact is that the meaning of disjunction in natural language is inclusive-*or*. In considering the input containing the disjunction operator ('or' in English), the underlying meaning of this logical operator is not immediately clear, even in cases where the inclusive-*or* interpretation of disjunction is permitted. Compare sentences (8) and (9) in a context in which there are blue, green and red balloons for Eric to choose from.

(8) Eric wants a red balloon or a green balloon.

(9) I bet Eric will choose a red balloon or a green balloon.

In response to (8), hearers generally infer that Eric wants just one balloon, either a red one or a green one. This is the exclusive-*or* reading of disjunction, according to which exactly one of the disjuncts is true. In response to (9), hearers generally infer that the speaker has made a correct prediction, so long as Eric chooses a red balloon or a green balloon, or both (but not a blue balloon). This is the inclusive-*or* reading of disjunction, which includes the possibility that both disjuncts are true.

Note, however, that the inclusive-*or* meaning of disjunction generates the truth conditions that are associated with the exclusive-*or* meaning. Based on this observation, among others, it has been argued that disjunction is always inclusive-*or* and that the exclusive-*or* meaning is derived when the additional truth condition that is associated with inclusive-*or* (where both disjuncts are true) is suppressed due to a conversational implicature. The implicature arises because the logical operators OR and AND form a scale, based on information strength. On the scale containing AND and OR, statements with AND are stronger than the corresponding statements with OR, where a term  $\alpha$  is 'stronger' than another term  $\beta$  if  $\alpha$  asymmetrically entails  $\beta$ . Since the truth conditions assigned to 'P and Q' are a subset of the truth conditions of 'P or Q', statements with AND asymmetrically entail the corresponding statements with OR, which are true in a wider range of circumstances. Following the Gricean conversational maxim of quantity (which entreats speakers to make their contributions as informative as possible), hearers generally assume that if a speaker uses OR, he or she is not in a position to use the stronger term AND to describe the situation under consideration (Grice 1975). Hearers therefore remove the truth conditions associated with AND from the 'basic' meaning of OR, yielding the exclusive-*or* reading of disjunctive statements (Horn 1996).

It turns out that children are sensitive to the fact that the underlying meaning of OR is inclusive-*or*. As noted earlier, reviews of the input to English-



speaking children on the CHILDES database reveal that, overwhelmingly, children hear sentences in which an exclusive-*or* meaning of disjunction is intended. In spite of the paucity of relevant input, several experimental studies have shown that 3- to 6-year-old children access an inclusive-*or* reading when disjunction words are presented in a context that is felicitous for this reading, such as in the antecedent of a conditional statement (Chierchia *et al.* 2004, Crain *et al.* 2000, Gualmini *et al.* 2000).

### 1.1.2. Logical Fact 2: Downward Entailing Expressions License Inferences from Sets to Subsets

The second logical fact is that there exists a class of expressions in human languages that are called DOWNWARD ENTAILING (DE), and these expressions license logically valid inferences from sets to subsets. This class encompasses both negative expressions like NOT, NONE, and WITHOUT, as well as non-negative expressions like the universal quantifier EVERY and the temporal conjunction BEFORE. Despite syntactic and semantic differences among these expressions, they form a natural class in human languages because they license downward entailing inferences from general terms (e.g., 'Romance language') to more specific terms (e.g., 'French').

Consider the statement 'John did not learn a Romance language'. This statement contains negation ('not') and the general term 'Romance language'. If this statement is true, then it logically follows that the statement 'John did not learn French' is also true, where the general term 'Romance language' has been replaced by the specific term 'French'. The universal quantifier 'every' also validates inferences from general terms to specific terms, so if the statement 'Every Romance language is offered for study at this university' is true, then it must also be true that 'French is offered for study at this university'. Note, however, that, as we discussed above, the universal quantifier presents an asymmetry across its arguments. It is only downward entailing on its first argument, and not on its second argument. So, 'Every student is taking a Romance language' does not necessarily entail that every student is taking French.

Child language acquisition data again provide evidence that children are sensitive to downward entailment (DE) in natural language, because children have been found to use this property to master a set of apparently unrelated linguistic facts. DE expressions have two main diagnostic properties. The first is that they license negative polarity items like 'any'. The second is that they license the conjunctive interpretation of disjunction. On a learning approach, one would expect children to master these two logical operators piecemeal, as they amass relevant input for each operator. On a nativist approach, by contrast, one would expect both properties to emerge together as early as they can be tested.

Let's look at the evidence that children know about the first diagnostic property of DE expressions. As the examples in (10) illustrate, the use of 'any' is licensed in DE contexts. By contrast, non-downward entailing contexts do not tolerate negative polarity items such as 'any'. Without a DE operator, sentences with 'any' are ungrammatical, as illustrated in (11).

- (10) a. Eric did not apply for any scholarship.  
 b. Every student of any Romance language should apply for a scholarship.  
 c. Benjamin applied for a scholarship before any other student.
- (11) a. \*Eric applied for any scholarship.  
 b. \*Every student who applied for a scholarship studies any Romance language.  
 c. \*Benjamin applied for a scholarship after any other student.

It has been shown that children adhere to this restriction on the use of negative polarity items from the earliest stages of language acquisition. Large-scale reviews of the spontaneous production data of both English-speaking children (aged 0;1–5;2) and Dutch-speaking children (aged 1;5–3;10) have revealed children almost never produce negative polarity items without a downward entailing licenser of some sort (Tieu 2010, van der Wal 1996).<sup>1</sup> In elicited production tasks, it has also been found that children do not produce negative polarity items in non-downward entailing environments, while they do produce them in downward entailing environments (Crain & Thornton 2006, O’Leary 1994, van der Wal 1996). The fact that children avoid and produce negative polarity items in just the right contexts shows that they are sensitive to the difference between downward entailing environments and non-downward entailing environments.

It is conceivable that children master the distribution of negative polarity items by keeping track of the statistical likelihood of each negative polarity item appearing in a range of linguistic environments. They could then use this information to classify which expressions in natural language are downward entailing. Even if this were the case, however, we would not necessarily expect children to be sensitive to the second diagnostic property of downward entailing expressions, the conjunctive interpretation of disjunction, at the same early stage of language development. If, on the other hand, children are innately sensitive to which expressions in language are and are not downward entailing, then we would expect them to compute a conjunctive interpretation of disjunction in DE environments as soon as they can be tested. In the next section, we will explain why this interpretation arises, before reviewing the available evidence showing that children do, indeed, access this interpretation. We will then look specifically at how the compound quantifier ‘not every’ also demonstrates this property.

### 1.1.3. *The Conjunctive Interpretation of Disjunction in the Scope of a DE Expression*

Downward entailing operators license a conjunctive interpretation of disjunction in one of two ways, depending on the type of DE operator in question. In both

---

<sup>1</sup> Children’s utterances may still be non-adult like at an early stage because they choose to use a downward entailing operator which is not the most appropriate in a certain context, or they use pseudo-licensing strategies (e.g., anaphoric ‘no’, headshaking, intonation contour) until their negation vocabulary has expanded enough to give them access to the correct variety of licensors (van der Waal, 1996).

cases, however, the conjunctive interpretation depends on the disjunction operator being assigned the truth conditions associated with inclusive disjunction (*inclusive-or*).

The first way the conjunctive interpretation of disjunction can arise pertains to all negatively flavored DE operators. We will illustrate using negation, as in (12).

- (12) John will not eat broccoli or cauliflower.  
 $\Rightarrow$  John will not eat broccoli and John will not eat cauliflower.

When disjunction is interpreted in the scope of negation, sentence (12) is understood to entail that John will not eat broccoli AND that John will not eat cauliflower. The logic is as follows. Ordinary statements with *inclusive-or* are true in three circumstances, just as in classical logic. In classical logic, a statement of the form 'P or Q' is true if:

- (i) P is true (but Q is not), or
- (ii) Q is true (but P is not), or
- (iii) both P and Q are true.

This means that 'P or Q' is false in just one circumstance: when neither P nor Q is true. When 'or' is negated, the truth conditions for *inclusive-or* are reversed. So 'not (P or Q)' is true in the one circumstance in which 'P or Q' is false, namely when neither P nor Q is true. This relationship is captured in one of de Morgan's laws of propositional logic (de Morgan, 1966), where the symbol ' $\neg$ ' stands for 'not', the symbol ' $\vee$ ' stands for 'or', and the symbol ' $\wedge$ ' stands for 'and':

- (13)  $\neg(P \vee Q) \Rightarrow \neg P \wedge \neg Q$

The second way the conjunctive interpretation of disjunction can arise pertains to all DE operators containing the universal quantifier in their semantics. We will illustrate using 'every', as in (1), repeated here as (14).

- (14) Every passenger who ordered chicken or beef became ill.  
 $\Rightarrow$  every passenger who ordered chicken became ill AND every passenger who ordered beef became ill (AND every passenger who ordered both became ill).

Sentence (14) is understood to entail that passengers who ordered chicken became ill AND passengers who ordered beef became ill. The logic, in this case, depends on the set relations that 'every' creates when it is in construction with a noun phrase that contains disjunction, such as 'every passenger who ordered chicken or beef'. A sentence containing a quantificational determiner is divided into three parts for the purpose of meaning computation: the quantifier, the restrictor and the nuclear scope (Heim 1988). The restrictor is the noun phrase with which the quantificational determiner combines syntactically. The nuclear scope is the predicate phrase. In the restrictor in (14), 'or' is used to partition the universally quantified superset 'every passenger' into two subsets 'passengers

who ordered chicken' and 'passengers who ordered beef'. The quantificational expression 'every passenger who ordered chicken or beef' refers to the entirety of the partitioned superset of passengers. This superset then necessarily includes:

- (i) passengers who ordered chicken,
- (ii) passengers who ordered beef, and
- (iii) passengers who ordered both chicken and beef.

Here, the conjunctive interpretation of disjunction arises because all THREE circumstances associated with inclusive-*or* must be true in order to guarantee the truth of the universally quantified statement. This contrasts with the conjunctive interpretation of disjunction in cases like (12), in which only ONE truth condition is satisfied: the one in which both disjuncts are false.

Once again, the evidence from the child language acquisition literature demonstrates that children are sensitive to this diagnostic property of downward entailing expressions, whether the DE expression is negatively or non-negatively flavored. Negative DE expressions which have been investigated include negation and the quantifier 'none'. It has been shown that both English- and Japanese-speaking 3- to 5-year-old children consistently assign a conjunctive interpretation to disjunction when it appears with negation in sentences like 'The pig did not eat a carrot or a pepper'. They reject the sentence as a description of a context in which the pig did not eat a carrot, but did eat a pepper (Crain *et al.* 2002, Goro & Akiba 2004a, b, Gualmini 2005, Gualmini & Crain 2005). This result has also been shown to hold in child English for the operator 'none' (Gualmini & Crain 2002).

Non-negative DE expressions which have been investigated include the temporal conjunction 'before' and the universal quantifier 'every'. It has been shown that both English- and Mandarin-speaking children consistently assign a conjunctive interpretation to disjunction when it appears with BEFORE in sentences like 'The dog reached the finish line before the turtle or the bunny'. On the conjunctive interpretation, the sentence means that the dog reached the finish line before the turtle AND before the bunny. Children reject such sentences as a description of a context in which a dog, a turtle and a bunny run a race, and the dog comes second (Notley *et al.* 2011). Furthermore, as we discussed in the introduction, both English- and Mandarin-speaking children have been shown to generate the conjunctive interpretation of disjunction in the subject phrase of the universal quantifier, but not in the predicate phrase. They reject sentences like 'every princess who picked a red flower or a white flower received a jewel' in contexts in which, for example, only princesses who picked red flowers received a jewel, and they accept sentences like 'every princess with a jewel picked a red flower or a white flower' in contexts in which every princess with a jewel picked a red flower (Boster & Crain 1993, Chierchia *et al.* 2001, Chierchia *et al.* 2004, Gualmini *et al.* 2003, Su & Crain 2009).

### ***1.2. The Conjunctive Interpretation of Disjunction in the Nuclear Scope of 'Not Every'***

Now let's consider how the conjunctive interpretation of disjunction arises in

sentences containing the compound quantifier 'not every'. As we have pointed out, negation reverses the entailment relations typical of 'every': 'not every' is downward entailing on its nuclear scope (predicate phrase), and not on its restrictor (subject phrase). Recall examples (5) and (6), repeated as (15) and (16).

- (15) Not every passenger who ordered chicken or beef became ill.
- a. Not every <sub>REST</sub>[passenger who ordered chicken OR beef] <sub>SCOPE</sub>[became ill].
  - b. Meaning: At least one passenger who ordered chicken OR beef was unaffected.
- (16) Not every passenger who became ill ordered chicken or beef.
- a. Not every <sub>REST</sub>[passenger who became ill] <sub>SCOPE</sub>[ordered chicken OR beef].
  - b. Meaning: At least one passenger who became ill did not order chicken AND did not order beef.

If disjunction is interpreted in the nuclear scope (predicate phrase) of 'not every' in (16), then a conjunctive interpretation is assigned to disjunction, such that there must be at least one sick passenger in the context who did not order chicken AND who did not order beef. To arrive at this meaning, two combinatory logical principles are required. The first dictates that 'not every' is logically equivalent in meaning to 'some not'. This logical equivalence can be represented by the logical rule given in (17) where the symbol ' $\forall$ ' stands for the universal quantifier 'every', the symbol ' $\exists$ ' stands for the existential quantifier 'some', A represents the restrictor, and B represents the nuclear scope. The meaning rule in (17) says that 'Not every A has the property B' is logically equivalent in meaning to 'Some A does not have the property B'. We will call this the 'not every = some not' equivalence.

$$(17) \quad \neg \forall (A) (B) \Rightarrow \exists (A) \neg(B)$$

When (17) is applied to sentence (16), a covert negation operator 'not' is made to act on the nuclear scope of the sentence: 'ordered chicken or beef'. This, in turn, means that the disjunction operator contained within the nuclear scope gets interpreted as if it were appearing in an overt negative downward entailing environment. Then, through the application of a second logical principle, namely de Morgan's law illustrated in (13), the conjunctive interpretation is computed. On the other hand, when (17) is applied to sentence (15), disjunction gets interpreted as if it were appearing in the restrictor of the existential quantifier. This is an upward entailing environment, not a downward entailing one. Subsequently, the meaning of (15) is that there must be at least one passenger who did not order chicken, or at least one passenger who did not order beef, who did not become ill, not one of each.

The reversal of entailment relations between 'every' and 'not every' provides us with a way of further testing whether the logical principles we have discussed are available to children from the outset of the acquisition of language. In the present study, the goal is to see whether or not children are sensitive the entailment expressed in (17). If so, then children are expected to assign a

conjunctive interpretation to disjunction when it appears in the nuclear scope of 'not every', but not when it appears in the restrictor.

We should point out here that our study was not designed to test whether children also cancel the scalar implicature associated with disjunction when it appears in the nuclear scope of 'not every', as opposed to the restrictor. Another notable feature of DE environments is the cancellation (or reversal) of scalar implicatures (Atlas & Levinson 1981). As discussed earlier, disjunction is subject to a scalar implicature in ordinary (positive) contexts, including the predicate phrase of the universal quantifier. That is why adult speakers generally reject a sentence like 'Every passenger who became ill ordered chicken or beef' as an accurate description of a context in which every sick passenger ordered both chicken and beef. Due to the application of a scalar implicature, hearers remove the truth condition on which every passenger ordered both meats. However, hearers judge a sentence like (14), *'Every passenger who ordered chicken or beef became ill'* to be true in exactly the same context. Because disjunction appears in the restrictor in (14), a downward entailing environment, the scalar implicature is cancelled, so hearers do not remove the truth condition on which every passenger ordered both meats from their interpretation. Indeed, this truth condition cannot be removed, because, due to the conjunctive interpretation of disjunction, all three truth conditions associated with disjunction hold in a universally quantified DE environment.

Notice, however, that it is not necessary to consider whether scalar implicatures are cancelled in order to see the conjunctive interpretation of disjunction at work in universally quantified contexts. For example, if a conjunctive interpretation of disjunction is computed in (14), then even if there are no passengers who ordered both kinds of meat, it is still necessary for both other truth conditions to be true: (i) that all sick passengers who ordered chicken became ill, and (ii) that all sick passengers who ordered beef became ill. If the conjunctive interpretation were not computed, then (14) could be true if only one of the truth conditions (i) or (ii) were true, but not both. In other words, if our goal is to determine whether or not a conjunctive interpretation of disjunction is computed in the restrictor of the universal quantifier, we do not need to worry about representing truth condition (iii) in the experimental workspace, according to which passengers who ordered both chicken and beef became ill. We can determine this by seeing if speakers reject (14) when just (i) or just (ii) is true, but accept (14) when both (i) and (ii) are true. We draw attention to this because the experimental contexts we use in the present study focus only on the first two possible truth conditions of our test sentences. We use these contexts to test whether children possibly (erroneously) access a conjunctive interpretation of disjunction in the restrictor of 'not every', not whether they cancel the relevant scalar implicature.

Having introduced the logic behind the interpretations assigned to disjunction in the restrictor and nuclear scope of 'not every', we now discuss the possible semantic scope ambiguity associated with sentences like (16), *'not every passenger who became ill ordered chicken or beef'*. To do so, we introduce some background about cases of semantic scope ambiguity involving disjunction and downward entailing operators in general, before moving on to the case of 'not

every'. We will then discuss the Semantic Subset Maxim, which makes a specific prediction about how children will resolve ambiguities of this kind.

### 1.3. *Cross-Linguistic Differences in Semantic Scope Assignment*

The logical principles we have presented (that the meaning of disjunction is inclusive-*or*; that DE expressions form a natural logical class; and that disjunction is assigned a conjunctive interpretation in DE environments) are proposed to be universal principles of all natural languages. There are, however, some interesting cross-linguistic differences in how various languages interpret sentences containing disjunction and a downward entailing operator, demonstrating that these sentences are subject to semantic scope ambiguity.

For example, sentences containing the DE operator negation and disjunction like (12), '*John will not eat broccoli or cauliflower*', actually have two possible interpretations. If disjunction is interpreted in the scope of negation, a conjunctive interpretation arises. Languages which prefer this scope assignment include English, German, French, Greek, Romanian, Bulgarian, and Korean (Szabolcsi 2002). If, on the other hand, disjunction is interpreted outside the scope of negation, no conjunctive interpretation arises. For example, in Japanese, sentence (18) is typically interpreted to mean 'it is broccoli or a cauliflower that Taro will not eat (I'm not sure which one)'.<sup>2</sup>

- (18) Taro-wa burokkori ka karifurawa-o tabe-nai. Japanese  
*Taro-TOP broccoli or cauliflower-ACC eat-NEG*  
 'Taro will not eat broccoli or cauliflower.'  
 ⇒ 'It is broccoli or cauliflower that Taro will not eat (I'm not sure which one).'

Other languages that prefer for disjunction to be interpreted as taking scope over negation in simple negative sentences include Hungarian, Mandarin, Russian, Serbo-Croatian, Slovak, and Polish (Goro & Akiba 2004a, b, Szabolcsi 2002). Due to the relation allowed between disjunction and negation in languages like these, disjunction typically implies exclusivity (e.g., 'it is either broccoli or cauliflower (but not both) that Taro doesn't like'). This is because disjunction is subject to exactly the same scalar implicature as it is when it appears in a sentence without negation.

This account of the interpretive differences between languages maintains that the basic meaning of disjunction in all human languages is inclusive-*or*, and that when inclusive-*or* appears in the semantic scope of a DE operator a conjunctive interpretation will necessarily be generated. In languages like Japanese in which an exclusive-*or* reading of disjunction is assigned to sentences

<sup>2</sup> The notion of scope under consideration does not depend on one operator appearing in a 'higher' structural position than the other in the syntactic tree corresponding to the sentence that is uttered (i.e. at spell-out). In both English and Japanese, negation is typically analyzed as residing in a higher node in the syntactic tree than disjunction, at spell-out. Nonetheless, disjunction is interpreted as taking semantic scope over negation in Japanese sentences like (18). To account for this reading in languages like Japanese, it is generally posited that disjunction has moved covertly at the level of logical form to a higher node in the syntactic tree for the computation of the sentence meaning.

like (18), it is supposed that disjunction takes semantic scope over negation. The disjunction operator is therefore not in a DE environment, and no conjunctive interpretation is generated.

Just as sentences containing negation and disjunction can be ambiguous, we discovered that sentences containing ‘not every’ and disjunction can also be ambiguous. Note that this ambiguity does not arise in sentences containing ‘every’. This is because when disjunction occurs in the restrictor of a quantifier, it is bound by that quantifier, and must be interpreted in its scope. When disjunction occurs in the nuclear scope of a quantifier, by contrast, two alternative scope relations become available. However, when disjunction occurs in the non-downward entailing nuclear scope of ‘every’ it receives its normal disjunctive interpretation regardless of the semantic scope of this quantifier (compare ‘every princess picked a red flower or a white flower’ to ‘it was a red flower or a white flower that every princess picked’). On the other hand, when disjunction occurs in the downward entailing nuclear scope of ‘not every’, two different readings are available. For example, sentence (7), repeated here as (19), receives two interpretations. If ‘not every’ takes scope over disjunction, disjunction receives the conjunctive interpretation indicated in 19(a). If disjunction takes scope over ‘not every’, disjunction receives the disjunctive interpretation indicated in 19(b). This is not the preferred interpretation for English-speaking adults, but it is a possible interpretation, as we will see in the results section.

- (19) Not every passenger who became ill ordered chicken or beef.
- a. Meaning 1: at least one passenger who became ill did not order chicken AND did not order beef.
  - b. Meaning 2: it was chicken or beef that not every passenger who became ill ordered.

It turns out that the two readings available for sentence (19) form a subset-superset relationship. That is, on the conjunctive interpretation of disjunction in 19(a), the only circumstance that will make the sentence true is if there is some sick passenger who ordered neither of the meats in question. On the alternative interpretation, in which disjunction takes scope over negation, there are three logical circumstances which will make the sentence true: (i) if some sick passenger didn’t order chicken, but did order beef, or (ii) if some sick passenger didn’t order beef, but did order chicken, or (iii) if some sick passenger ordered neither meat. The circumstances that would make the sentence true on a conjunctive interpretation are thus contained within the circumstances that would make the sentence true on a disjunctive interpretation. It has been proposed that in a situation like this, children should be constrained by learnability considerations as to which reading they will initially hypothesize. We outline this hypothesis and its prediction for our study in the next section.

#### 1.4. *The Semantic Subset Maxim (SSM)*

The Semantic Subset Maxim (SSM) becomes operative when a sentence has two possible scope interpretations, and these two interpretations form a subset-



superset relationship. Once engaged, the SSM compels children to initially favor the reading that makes the sentence true in the narrowest range of circumstances, the subset reading (see Notley *et al.* 2011). The rationale behind the SSM is that it prevents unnecessary delays for children in acquiring the scope assignment preferences manifested by adult speakers of the local language. If children are acquiring a language in which the superset reading of a sentence is favored by adult speakers, then the SSM guarantees that children who have an initial preference for the subset reading will encounter positive evidence in the input demonstrating that the sentence is true on a wider set of interpretations. Based on the evidence, children will then be able to quickly align their preferences with those of adult speakers. If, on the other hand, children initially favor the superset reading, then the majority of the input they receive will always be consistent with that interpretation, including input from speakers who strongly prefer a subset reading. It would therefore take children considerably longer to align their preferences with those of the adults around them on this scenario.

The findings we discussed previously showing that children, across languages, assign a conjunctive interpretation to disjunction in various downward entailing contexts provide support for the SSM. In particular, the results showing that Japanese- and Mandarin-speaking children prefer to assign a subset conjunctive interpretation to sentences like 'the pig did not eat the carrot or the pepper' or 'the dog reached the finish line before the turtle or the bunny' are particularly telling. This is because, in these languages, adult controls actually preferred or, at least, allowed a superset reading in which disjunction was assigned wide scope over the DE operator in question (Goro & Akiba 2004b, Notley *et al.* 2011).

We can use the scope ambiguity introduced in sentences containing 'not every' and disjunction to further test the SSM. The SSM would predict that children should strongly prefer to assign the conjunctive interpretation, 19(a), to sentences like (19). The conjunctive interpretation makes the sentence true in the narrowest set of circumstances. Children can then easily expand their scope preferences to include alternative interpretations based on positive evidence provided by adult language users.<sup>3</sup> We turn now to our methodology, explaining how our study was designed to both test the logical principles outlined, and the predictions of the SSM.

## 2. Methodology

To test children's interpretation of disjunction in the nuclear scope and restrictor of 'not every' we designed a truth value judgment task (TVJT). This research technique is designed to investigate which meanings children can and cannot assign to sentences (Crain & Thornton 1998). The task involves two experi-

---

<sup>3</sup> We are not committed to this evidence coming from sentences like (19) being used in a context in which, for example, not every sick passenger ate chicken, but every sick passenger did eat beef. Evidence from other types of sentences containing a DE operator and disjunction, used in a context in which disjunction is interpreted as scoping over the DE operator, would probably suffice.

menters — one acting out stories with toy characters and props, and the other playing the role of a puppet who watches the stories alongside the child. At the end of each story, the puppet explains to the child subject what he thinks happened in the story. The child’s task is to decide whether the puppet said the right thing or not. If the child informs the puppet that he was wrong, then the child is asked to explain to the puppet what really happened. There were two test conditions: one in which ‘or’ appeared in the nuclear scope of ‘not every’; and one in which ‘or’ appeared in the restrictor of ‘not every’. We will refer to these conditions as the ‘Nuclear Scope OR’ condition and the ‘Restrictor OR’ condition. Each condition had 4 trials, yielding 8 different test items. Each condition is illustrated below, followed by the relevant predictions.

### 2.1. *‘Nuclear Scope OR’ Condition*

In the ‘Nuclear Scope OR’ condition there were four test stories like this one:

“Here is an enchanted castle where there is some hidden treasure: silver stars, crystal shells, and golden crowns. And here are four princesses who have been having a picnic in the woods nearby, and are now walking home. One of the princesses spies the palace. “Oh what a beautiful palace,” she says. “Let’s go and see what’s inside.” They go in and see some crystal shells. Two of the princesses take a shell each. The other two want to look for something better. Then the princesses go upstairs. The two princesses with shells see a pile of silver stars — they each take one. The other two still want to look for something better. They continue looking and find a secret room with golden crowns in it. But they already have crowns on their heads. So they decide not to take the crowns. Instead, they go back to the pile of stars and each take one. The princesses are happy with the treasure they have chosen to take home.”



Figure 1: FALSE ‘Nuclear Scope OR’ Condition

Figure 1, which corresponds to the scene at the end of the story, illustrates this condition. After the story, the puppet watching alongside the child uttered test sentence (20) to describe what he thought happened in the story. Note that each test sentence was preceded by a positive lead-in, such as 'every princess took some treasure'. This was because it has been shown that negative statements about stories are often pragmatically infelicitous and can lead to irrelevant errors by child subjects. A positive lead-in sentence preceding the negative statement helps to satisfy the pragmatic felicity conditions associated with negation and, as a consequence, is likely to reduce the number of irrelevant errors committed by children (Gualmini 2005, Musolino & Lidz 2006).

- (20) That was a story about four princesses looking for treasure. Every princess took some treasure and I know: Not every princess took a shell or a star.

On the conjunctive interpretation of disjunction, (20) is true if there is at least one princess who did not take a shell and who did not take a star. However, in all 4 trials in this condition, the context was, in fact, designed to make this reading false. For example, in our princess story, even though some princesses didn't take shells, they all did take stars. There was therefore no princess who did not take a shell and who did not take a star.

Part of the TVJT methodology recommends that when making a test sentence false, the context should fulfill the condition of plausible dissent. That is, the context should make clear to the child another possible outcome on which the test sentence would have been true. So, in all our 'Nuclear Scope OR' stories, a possible outcome was outlined in which two of the four characters might not have done either of the actions mentioned. For example, in the case of the princesses, two princesses did not take shells, and they also initially rejected stars, in search of something better. They almost took some crowns. This would have made test sentence (20) true on a conjunctive interpretation of disjunction. Finally, however, the princesses decided that they didn't need crowns because they already had crowns, so, in the end, they each took a star. By including a positive lead-in and satisfying the condition of plausible dissent, it is unlikely that children's responses in this task are due to pragmatic confusion. In addition, we always ordered the disjuncts so that the disjunct that made each test sentence false on the conjunctive interpretation was second. In this way we ruled out the possibility that children's rejections were due to the fact that they only listened to the first part of a test sentence (e.g., not every princess took a shell). If this were the case, the child would accept, not reject, the test sentences.

While the context of all the stories in the 'Nuclear Scope OR' condition made the test sentences false on the conjunctive interpretation of disjunction, the stories were also designed to make the test sentences true if children, in fact, do not compute the conjunctive interpretation of disjunction in the nuclear scope of 'not every'. They might do this either because they prefer a reading on which disjunction scopes over 'not every', or because, even though they assign 'not every' scope over disjunction, they do not apply the necessary logical principles in these contexts. In either case, sentence (20) could possibly mean 'not every princess took a shell OR not every princess took a star (OR not every princess took

a star or a shell). In our princess story, it was true that not every princess took a shell, making the overall disjunctive statement 'Not every princess took a shell OR not every princess took a star' true.

Let's now consider what our prediction in this condition is. To reject the test sentences in this condition, children must (a) recognize that 'not every' is downward entailing on its nuclear scope, and (b) assign 'not every' semantic scope over 'or'. Only the combination of these two conditions will ensure that children are then able to calculate a conjunctive interpretation of disjunction, and reject the test sentences. Therefore, a majority of child rejections in the 'Nuclear Scope OR' condition will show, first, that children are guided by the logical principles presented. Moreover, this will be new evidence that children make complex logical computations involving the 'not every = some not' equivalence. Second, rejections in this condition will constitute support for the Semantic Subset Maxim (which encourages children to favor the scope assignment which leads to a narrower, stronger reading of the sentence in question).

On the other hand, child acceptances in this condition could be indicative of two states of affairs. It could be that children are aware of the logical principles, but that they assign 'or' semantic scope over 'not every'. This would be evidence against the Semantic Subset Maxim, as by assigning 'or' semantic scope over 'not every', children access a wider possible meaning of test sentences like (20). Alternatively, it could be that children do not recognize that 'not every' is downward entailing on its nuclear scope. The relevant prediction is summarized below.

Prediction 1: If children are guided by innate logical principles, and by the SSM, then they should reject the 'Nuclear Scope-OR' test sentences (at a rate at least higher than 50% across children). If children are not guided by logical principles and the SSM, they could accept the sentences.

## 2.2. *'Restrictor OR' Condition*

In the 'Restrictor OR' condition there were two test stories like this one:

"This is a story about Mrs. Mouse's toyshop. She has balls and books for sale in her shop. Here come two little boys and two little girls. The first little boy comes into the shop. "Hi Mrs. Mouse, I'm allowed to buy something in your shop today, what do you have for sale?" Hmmm, balls and books. The little boy decides on a ball. The next little girl also buys a ball. Then the last little girl and boy come into the shop. "Hi Mrs. Mouse. We saw our friends bought balls, but do you have anything else for sale?" Mrs. Mouse shows them the books. They are both considering books, but finally the little boy decides to take a ball. The last little girl really likes the books and she decides to buy one of those instead."



Figure 2: TRUE 'Restrictor OR' Condition

Figure 2, which corresponds to the scene at the end of the story, illustrates this condition. After the story, the puppet watching alongside the child uttered test sentence (21) to describe what he thought happened in the story.

- (21) That was a story about Mrs. Mouse's toyshop and the children who came to the shop. Every child bought something, and I know: Not every girl or boy bought a ball.

In the 'Restrictor OR' test trials, a conjunctive interpretation does not arise, so sentence (21) does not mean that there must be both a girl and a boy who did not buy a ball; if only one girl or one boy did not buy a ball, this is sufficient to make the sentence true. In 2 of the 4 trials in this condition, the context was designed to make the test sentence true in this way — because only one character failed to complete an action. At the same time these contexts made the test sentence false if children incorrectly computed a conjunctive interpretation of disjunction in the restrictor of 'not every'. In this case, sentence (21) would mean 'there is some girl who did not buy a ball AND there is some boy who did not buy a ball'.<sup>4</sup> In our toyshop story it was not true that 'some boy did not buy a ball', so the overall conjunctive statement 'not every girl bought a ball AND not every boy bought a ball' was false.

To make this potential reading as clear as possible, each story was designed so that one member of each group of participants (e.g., one girl and one boy) performed an action (e.g., buying a ball). Then towards the end of the story, the other member in each group hesitated to carry out the same action (e.g., both the second girl and boy consider buying books). At the early point in the story, then, a possible outcome was that 'not every girl bought a ball AND not every boy

<sup>4</sup> Or more precisely that there must be both a girl, and a boy, and any individual who is both a girl and a boy, who did not buy a ball. As we have discussed the third possible truth condition cannot apply in these contexts, but the two remaining truth conditions are sufficient to test whether the conjunctive interpretation of disjunction is computed or not.

bought a ball'. Introducing a possible outcome in this way satisfies the condition of plausible dissent, making it felicitous for the child to reject the test sentence based on the actual outcome. The actual outcome made the test sentence false on a non-adult reading, because as the story unfolded, the second boy decided to buy a ball. The contrast between the possible outcome and the actual outcome makes it clear to the child why the sentence might be rejected. As with the 'Nuclear Scope OR' condition, in this condition, too, the disjuncts were ordered such that the second disjunct made the sentence false on a non-adult reading. In this way, we ensured that children's rejections could be attributed to the fact that they had erroneously computed a conjunctive interpretation of disjunction in the restrictor of 'not every', rather than because, say, children were simply not processing the full disjunctive statement. On the other hand, if children accessed the adult meaning of these sentences, they should have accepted them.

To control for the fact that children can also give a 'yes' response in situations where they are simply confused or fail to comprehend a sentence (Crain & Thornton 1998), the other two trials in this condition were designed to make the test sentence false. An example is given below.

"Here are two caterpillars and two crocodiles who are going to try to make their way through a maze. Mickey Mouse is the judge. He is waiting at the end of the maze with some prizes. If an animal can make it to the end, they can choose a yo-yo or some flowers as their prize. Ok, here goes the first caterpillar. He manages to make it to the end and he chooses a yo-yo. Now the first crocodile is having a turn. He gets a bit stuck, but eventually makes it to the end. He decides to take a yo-yo too. Now the second caterpillar is having his turn. He makes it to the end too. He considers the flowers, which have nice juicy leaves he could eat, but in the end decides to take a yo-yo too. Finally, the last crocodile goes through the maze. He goes round and round but finally makes it to the end. He chooses a yo-yo for his prize too."



Figure 3: FALSE 'Restrictor OR' Condition

Figure 3, which corresponds to the scene at the end of the story, illustrates this condition. After the story, the puppet watching alongside the child uttered test sentence (22) to describe what he thought happened in the story.

- (22) That was a story about some caterpillars and some crocodiles in a maze. Every animal reached the end of the maze and got a prize and I know: Not every caterpillar or crocodile choose a yo-yo.

In the two trials of this type, the context made the test sentence false; that is, there was no character who failed to fulfill the action described (such as choosing a yo-yo as a prize). Note that this context is necessarily false on both the adult reading of the sentence, and the possible non-adult reading (in which both a caterpillar and a crocodile must fail to choose a yo-yo). Therefore, these rejections alone do not allow us to draw any conclusions about children's interpretation of disjunction in these sentences. However, taken in combination with their responses to the true 'Restrictor OR' trials, the overall pattern of responses in this condition will reveal whether children are accessing the adult reading. A majority of 'no' responses across all 4 trials will mean children are accessing a non-adult meaning; a majority of 'yes' responses across all 4 trials will mean children are confused by the test sentence; while a consistent pattern of 'yes' and 'no' responses will reveal adult-like knowledge of the meaning of the test sentences.

Let's now consider what we predict for this condition. If children are guided by the logical principles we outlined, then they should demonstrate a different interpretation of disjunction in this context, as opposed to the 'Nuclear Scope OR' contexts. That is, children should be aware that, despite the fact that 'not every' is downward entailing on its nuclear scope, it is not downward entailing on its restrictor. Therefore, children should accept our true 'Restrictor OR' trials and reject our false 'Restrictor OR' trials. If, on the other hand, children fail to recognize that negation reverses the entailment relations of the quantifier 'every', they could erroneously compute a conjunctive interpretation of disjunction in the restrictor, and reject both types of 'Restrictor OR' trial. These predicted outcomes are summarized below.

- Prediction 2: If children are guided by logical principles, they should accept the adult-true 'Restrictor-OR' test sentences and reject the adult-false 'Restrictor-OR' test sentences. Otherwise, they could reject both the adult-true and adult-false 'Restrictor-OR' test sentences.

### 2.3. *Control Condition*

In addition to the two test conditions, we included a control condition to check that children could respond to sentences containing the compound quantifier 'not every', without the complicating factor of disjunction. These controls were administered following two stories identical in form to the 'Nuclear Scope OR' condition stories, but using different characters. After each control story, the puppet uttered two control sentences like (23). There were thus a total of 4 control sentences.



(23) Not every pirate caught a horse.

Note that, because ‘not every’ is a compound quantifier, it is not possible for the two composite parts of this determiner to enter into a scope relation with each other. This means that sentences like (23) are always assigned a reading in which some pirates did not catch horses (but typically some did). We will call this the ‘not all’ reading. Although sentences like (23) are also theoretically true on the ‘not all’ interpretation if no pirate catches a horse (i.e. it is certainly true that if none of the pirates caught a horse that not all of them did), this truth condition is generally ruled out for adults by the application of a scalar implicature. Accordingly, two of our control sentences described contexts in which, for example, two of four pirates had caught horses, but the other two had not. These controls were thus clearly true for adults and we will call them the adult-true controls. The other two controls described contexts in which, for example, all four pirates had caught horses. These controls were thus false for adults and we will call them the adult-false controls.

We included the controls to allow for the possibility that children do not interpret ‘not every’ as a compound quantifier, but rather as two separate logical operators that can take scope over each other. In this case, one possible scope assignment would be to assign ‘not’ wide scope over ‘every’. This results in the ‘not all’ reading, identical to the adult interpretation of the compound quantifier. The other possible scope assignment would be to assign ‘every’ wide scope over ‘not’. This results in a ‘none’ reading, and sentence (23) would mean that no pirate caught a horse. This ‘none’ reading is a narrower, stronger meaning of the sentence than the ‘not all’ reading (which, as we pointed out above, is true if just some pirates do not catch horses, or if none of them do). As such, according to the SSM, if children do interpret the compound quantifier ‘not every’ as two separate scope-bearing elements, then they should tend to access a ‘none’ reading of our control sentences. In this case we would expect to see children reject the adult-true controls, as well as the adult-false controls. Alternatively, if they successfully analyze ‘not every’ as a compound quantifier then we expect to see children accept the adult-true controls, and reject the adult-false controls. A third possible state of affairs is that children do not successfully analyze ‘not every’ as a compound quantifier, but they also do not preferentially assign ‘every’ wide scope over ‘not’, contra the predictions of the SSM. The overall percentage of children’s responses to the adult-true control condition should allow us to distinguish between these scenarios. Here is the relevant prediction:

**Prediction 3:** If children erroneously apply scope to ‘every’ and ‘not’ as separate operators, and the SSM holds, then they should prefer a ‘none’ reading of the adult-true control sentences, and reject the adult-true control sentences more than 50% of the time (or at least around 50% of the time if the SSM does not hold, and they therefore have no preference between the ‘not all’ and ‘none’ readings of the sentences).

If children do not apply scope to ‘every’ and ‘not’ as separate



operators, then they should access the 'not all' reading of the adult-true control sentences, and accept the adult-true control sentences more than 50% of the time.

It was important to control for the children's analysis of 'not every' without disjunction, because any child who failed the adult-true controls (showing that they perhaps allowed 'every' to take scope over 'not') might also allow 'every' to take scope over 'not' in our test condition sentences. In this case, they might interpret a sentence in the 'Nuclear Scope OR' condition like 'not every princess took a shell or a star' to mean that no princess took either of the objects in question, or that no princess took one of the objects in question. On either of these possible interpretations, our test sentences in the 'Nuclear Scope OR' condition would be false (because at least some of the princesses took shells, and all of them took stars). We would thus not be able to tell whether a child's rejections in this condition were due to their being guided by logical principles and the SSM (Prediction 1) or due to an erroneous analysis of the compound quantifier 'not every'.

Similarly, a child who failed the adult-true controls might interpret a sentence in the 'Restrictor OR' condition like 'not every boy or girl bought a ball' to mean that no boy and no girl bought a ball, or that either no boy or no girl bought a ball. On either of these possible interpretations, our test sentences in the 'Restrictor OR' condition would also be false (because three children did buy balls, including both boys and girls). We would thus not be able to tell whether the child's rejections in this condition were due to a failure to recognize that negation reverses the entailment relations of 'every' (Prediction 2) or again, due to an erroneous analysis of the compound quantifier 'not every'. On the other hand, for children who pass the controls, we can be confident that our predictions for both the 'Nuclear Scope OR' and 'Restrictor OR' conditions hold.

#### **2.4. Subjects**

We tested 22 English-speaking children (14 male, 8 female) between the ages of 4;2 and 5;2 (mean age 4;8). The child subjects were recruited from two child-care centers at Macquarie University, Sydney, Australia. In addition, 19 English-speaking adults were tested as controls (4 male, 15 female) between the ages of 19 and 27 (mean age 21). All were undergraduate students at Macquarie University.

#### **2.5. Procedure**

The 8 test and 4 control items (12 items in total) were administered in a pseudo-random order, interspersed with filler items (10 items in total). On these filler items, the puppet produced statements like (24) and (25), which were either obviously true or obviously false. As with the target sentences, the filler items were preceded by a lead-in sentence that made them felicitous in the context.

(24) What the first princess did was choose a purple shell and a silver star.

(25) Choose a red yo-yo is what the last crocodile did.

These filler items were included to balance the overall number of true and false sentences, to check that the child could answer both 'yes' and 'no' correctly, and to obscure the purpose of the experiment.

The children were tested individually in a quiet corner of their day-care centre. Each child was introduced to our puppet, Cookie Monster, and given two practice items before the actual test, one in which Cookie Monster made an obviously true statement about a story, and one in which he made an obviously false statement about a story. This was so that children would know that the puppet could say something wrong. These practice items were also used to familiarize children with the task. The full test was only administered to those children who correctly responded to the puppet's statements in the practice items. Because the stories were quite involved and the test sentences relatively difficult, the test, control and filler items were divided in half and presented over two sessions to reduce fatigue. Each session included 4 test items, 2 control items and 5 fillers. The full list and ordering of test materials for the two sessions is given in Appendix A.

To test the 19 adult subjects, the stories were video recorded. The adults were then tested in small groups of 3-5 participants. They watched the stories and recorded whether they thought each test sentence was a true or false description of the story on an answer sheet. They were always asked to justify their answer, whether they judged the test sentence to be true or false, so the answer sheet introduced no bias in how they should respond to any particular test sentence. Also, in that way they would not be aware if they were responding similarly or differently to other participants in their group, as all participants spent about the same time writing after the presentation of each test sentence.

### 3. Results

Five children were excluded from the data analysis either because they answered incorrectly on more than one filler item (2 children), or because they answered incorrectly on more than one control item (3 children). In total, the results of 17 children (11 boys, 6 girls), aged 4;2-5;2 (mean age 4;8) are presented below. We coded each subject's initial response to the test sentences. Self-corrections were accepted only if the test sentence had not been repeated. Both the child's true or false judgment of each sentence, as well as their justification for their answers, were taken into consideration in coding the data. Only answers in which the justification matched the judgment were considered in the final analysis.

On some occasions both children and adults gave responses in which their justification did not appropriately account for their judgment. For example, sometimes they gave mismatched responses, in which they provided a justification typical of a false judgment, but they accepted the test sentence, or vice versa. On other occasions some children gave justifications referring to extra objects in the context. All the test and control stories always had plenty of extra objects in the context that did not get acted on at all. For example, in the princess

story, at the end of the story, there were several leftover shells and stars in the castle. This was done because much work on children's and adult's interpretation of the universal quantifier has shown that a single leftover object in the context can affect pragmatic felicity. Although adults can generally cope with this infelicity, it can mislead children, who then judge stories on the fact that an object was left-over, rather than on the truth content of the test sentences (Crain *et al.* 1996, Freeman *et al.* 1982, Meroni *et al.* 2001). Although we tried to satisfy pragmatic felicity by including plenty of extra objects (rather than just one), occasionally children still gave an answer based on extra objects in the context. In short, any answers like these, in which a justification did not appropriately account for a judgment, were coded as 'Other', and were not included in the final counts of rejections and acceptances.

### 3.1. Control Results

Each child was given 2 adult-false controls and 2 adult-true controls. The 17 children included in further analysis successfully accepted the adult-true control sentences 91% of the time (31/34 trials). The 3 rejections in this condition came from 3 separate children, rather than from one child consistently. The children also rejected the adult-false controls 88% of the time (30/34 trials). These rejections were accompanied by justifications explaining that in fact, all the characters in question had performed some action. For example, in response to the adult-false control '*not every pirate caught a dinosaur*', a child aged 4;5 said 'no, because all of the pirates caught dinosaurs'. There were 2 acceptances of an adult-false control (from 2 separate children). The remaining 2 responses (also from 2 separate children) were coded as 'Other' because the children justified their answers by referring to objects left over in the testing context, rather than to the characters in question. A Wilcoxon Signed Ranks test showed the difference between the children's acceptance rates in the two control conditions to be significant ( $Z = 3.79$ ,  $p < 0.001$ ). According to Prediction 3, because the acceptance rate for the adult-true trials is well above 50% for children, we can be confident that those children who were included in the subsequent data analysis treated 'not every' as a compound quantifier, assigning it a 'not all' meaning.<sup>5</sup>

The 19 adults tested successfully accepted all their adult-true control trials 100% of the time (38/38 trials). They rejected their adult-false control trials 92% of the time (35/38 trials). Two adults did accept one of these trials each. These acceptances were both in response to the sentence 'Not every pirate caught a dinosaur' in a context in which two pirates caught dinosaurs, and two pirates caught dinosaurs and horses. The adults accepted the test sentence, explaining

---

<sup>5</sup> It is also possible that children accepted the adult-true control sentences because, despite treating 'not' and 'every' as two separate scope-bearing elements, children preferred to interpret 'not' as taking scope over 'every', given that the 'not all' meaning of 'not every' would be the only meaning modeled for them in the input. In the introduction, however, we reported that we found no instances of 'not every' in a large survey of input. Moreover, we also reported that several cross-linguistic studies have shown that children do not necessarily prefer the scope relationships modeled for them in the input. For these reasons, we think this is a less likely explanation of our data than the one we have offered here, that children successfully analyzed 'not every' as a compound quantifier.

that, indeed, only two pirates had caught ONLY dinosaurs. One adult failed to respond on one trial. The child and adult responses to the two types of control sentences are summarized in Table 1. A Mann-Whitney test showed no significant difference between children's and adult's acceptance rates to the controls either to adult-false trials ( $Z = 0.11$ ,  $p = 0.950$ ) or adult-true trials ( $Z = 1.87$ ,  $p = 0.379$ ).

	Response	Children N=17	Adults N=19
<b>Adult False</b>	Rejection	88% (30/34 trials)	92% (35/38 trials)
	Acceptance	6% (2/34 trials)	5% (2/38 trials)
	Other	6% (2/34 trials)	3% (1/38 trials)
<b>Adult True</b>	Rejection	9% (3/34 trials)	0% (0/38 trials)
	Acceptance	91% (31/34 trials)	100% (38/38 trials)
	Other	0% (0/38 trials)	0% (0/38 trials)

Table 1: Child and Adult Control Results

### 3.2. 'Nuclear Scope OR' Condition Results

Each child was given 4 trials in the 'Nuclear Scope OR' condition giving a total of 68 trials for analysis. The total rejection rate was 82% (56/68 trials). These 56 rejections comprised 2 different kinds of responses. In 46 of the 56 rejections the children provided an adult-like justification for their answer (typically referring to the fact that all four characters in the story had performed some action). These answers were coded as 'False – Correct Justification'. An example of this type of response from a child aged 4;5 is given in (26).

(26) Puppet: Not every princess took a shell or a star.

Child: every princess, not every princess took a shell, that was correct, but every, but every...every of these people have a star.

On the other 10 trials (from 6 different children), the children judged the test sentences to be false, but their justifications referred to the fact that two characters in the story had not performed some action (rather than to the fact that all four had performed some action). We included these in the overall count of false judgements, and coded them as 'False – Inverted Justification'. This probably occurred because of the difficulty involved in justifying a negative judgment about a negative sentence. In fact, the correct justification involves explaining that the FAILURE to perform some action (by some characters) is

correct, and that the SUCCESS in performing some other action (by all characters) is incorrect. So, although the children who gave 'False – Inverted Justification' responses did judge the sentences to be incorrect descriptions of the story they had just heard, they then had trouble explaining which part of the context had not been correctly described. They offered the failure to perform some action as a more pragmatically felicitous justification of what made the test sentence incorrect than the success in performing some other action. An example of this type of response from a child aged 4;8 is given in (27).

(27) Puppet: Not every princess took a shell or a star.

Child: every princess got a star, but not, not all of them got these [shells].

Puppet: so was I right or wrong?

Child: um right for the stars and wrong for the shells.

Children accepted trials in this condition 10% of the time (7/68 trials), and these acceptances came from 7 different children, rather than from one child consistently. The remaining responses were coded as 'Other' because either the child gave no answer (1 trial), an answer related to objects left-over in the testing context, or some other justification not clearly related to the test sentence (2 trials), or a mismatched answer in which they provided a correct justification for a rejection, but then accepted the test sentence (2 trials). These other responses accounted for 7% of the data (5/68 trials).

The 19 adults tested also responded to 4 trials each, giving a total of 76 trials for analysis. The total rejection rate was 68% (52/76 trials). In 51 of the 52 rejections, adults offered a justification for their answer referring to the fact that all four characters in the story had performed an action. However, on one trial, one adult did give an 'Inverted Justification'. This shows that, even for adults, justifying a negative judgment about a negative sentence can be difficult pragmatically. The adults accepted their 'Nuclear Scope OR' trials 25% of the time (19/76 trials). In justification of these acceptances, the adults offered the kind of explanations that we had allowed for in the context if disjunction were allowed to scope over 'not every', making a statement like 'Not every princess took a shell or a star' possibly true if, for example, not every princess took a shell. An example of this kind of response is given in (28).

(28) Test sentence: Not every frog jumped over the fence or the pond.

Response: True, not every frog jumped over the fence.

The remaining adult responses were coded as 'Other' because either they gave no answer (1 trial), an answer related to objects left-over in the testing context (2 trials), or a mismatched answer in which they provided a correct justification for a rejection, but judged the test sentence to be true (2 trials). These other responses accounted for 7% of the data (5/76 trials).

The child and adult responses in this condition are summarized in Table 2. A Mann-Whitney test showed no significant difference between children's and adult's rejection rates in this condition ( $Z = 1.34$ ,  $p = 0.232$ ).

Response	Children N=17	Adults N=19
<b>False – Correct Justification</b>	67.7% (46/68 trials)	67.1% (51/76 trials)
<b>False – Inverted Justification</b>	14.7% (10/68 trials)	1.3% (1/76 trials)
<b>Total Rejection</b>	<b>82.4%</b> <b>(56/68 trials)</b>	<b>68.4%</b> <b>(52/76 trials)</b>
<b>True</b>	10.3% (7/68 trials)	25.0% (19/76 trials)
<b>Other</b>	7.3% (5/68 trials)	6.6% (5/76 trials)

Table 2: Child and Adult 'Nuclear Scope OR' Condition Results

### 3.3. 'Restrictor OR' Condition Results

Each child was given 2 true trials and 2 false trials in the 'Restrictor OR' condition, giving a total of 34 true trials and 34 false trials for analysis. The children accepted their true 'Restrictor OR' trials 65% of the time (22/34 trials). There were 5 rejections of true trials (from 5 separate children). In these cases the children gave justifications for their answers referring to the fact that all the members of one of the sets of actors had, in fact, performed the action in question. To illustrate, an example from a child aged 4;6 is given in (29), although no child consistently responded to these trials in this way.

- (29) Puppet: Not every fish or dolphin swam through a square.  
 Child: every fish went to the square and one dolphin went to the square.  
 Puppet: oh it was a hard one for me, not every fish or dolphin swam through a square, right or wrong?  
 Child: wrong.

Rejections like these accounted for 15% of the data (5/34 trials). The remaining 7 trials were coded as 'Other' because either the child gave no answer (1 trial), an answer related to objects left-over in the testing context (2 trials), or a mismatched answer in which a correct justification was provided for an acceptance (by talking about the one character who had, indeed, not performed the action in question), but the children then rejected the test sentence (4 trials). These other responses accounted for 20% of the data (7/34 trials).

The children rejected their false 'Restrictor OR' trials 94% of the time (32/34 trials). One child accepted one false trial, and one trial was coded as 'Other' because a child provided a mismatched answer in which he provided a correct justification for a rejection, but accepted the test sentence. A Wilcoxon Signed Ranks test showed the difference between the children's acceptance rates to the true and false test sentences in the 'Restrictor OR' condition to be significant ( $Z = 3.52$ ,  $p < 0.001$ ). The strong rejection rate in response to the false 'Restrictor OR' trials means we can be confident that the children's acceptances of the true trials

are genuine acceptances, rather than the result of confusion.

The 19 adults tested also responded to 2 true and 2 false trials each, giving a total of 38 true and 38 false trials for analysis. The adults accepted their true trials 92% of the time (35/38 trials). The remaining 3 trials were coded as 'Other'. These trials all related to our story about fish and dolphins swimming through shapes. Because the positive lead-in to this story's test sentence was 'Every animal swam through a shape', 3 adults judged this to be false because a stingray in the story, who was introduced as the teacher at fish school, did not swim through any shape. The adults rejected their false 'Restrictor OR' trials 100% of the time (38/38 trials).

The child and adult responses in this condition are summarized in Table 3. A 2 (Age: child, adult)  $\times$  2 (Condition: true, false) ANOVA was carried out on the results with acceptance rate as the dependent measure. There was a main effect of condition,  $F(3,71) = 575.61$ ,  $p < 0.000$ , but no main effect of age. Both children and adults tended to accept the true 'Restrictor OR' trials and reject the false ones. However, there was also an interaction effect of condition and age,  $F(3,71) = 7.58$ ,  $p < 0.01$ . So, children tended to accept their true trials less often than adults, while accepting their false trials more often than adults. This is not surprising, however, given that adults performed more at less at ceiling in this condition. Post-hoc Mann-Whitney pair-wise comparisons revealed that there was actually no significant difference between children's and adult's acceptance rates in this condition in response to false trials ( $Z = 1.06$ ,  $p = 0.778$ ). However, there was a significant difference between the two groups' acceptance rates in response to true trials ( $Z = 2.99$ ,  $p < 0.05$ ).

	<b>Response</b>	<b>Children N=17</b>	<b>Adults N=19</b>
<b>True 'Restrictor OR'</b>	Acceptance	64.7% (22/34 trials)	92.1% (35/38 trials)
	Rejection	14.7% (5/34 trials)	0% (0/38 trials)
	Other	20.6% (7/34 trials)	7.9% (3/38 trials)
<b>False 'Restrictor OR'</b>	Acceptance	2.9% (1/34 trials)	0% (0/38 trials)
	Rejection	94.1% (32/34 trials)	100% (38/38 trials)
	Other	2.9% (1/34 trials)	0% (0/38 trials)

Table 3: Child and Adult 'Restrictor OR' Condition Results

#### 4. Discussion

This study investigated 4- to 5-year-old English-speaking children's interpretation of disjunction in both the nuclear scope and in the restrictor of the compound quantifier 'not every'. The aim of this investigation was two-fold. The first aim was to assess the extent to which children are guided by logical principles in their interpretation of sentences containing multiple logical operators. Given that these sentences are not readily available in the primary linguistic data, children's responses to such sentences could be revealing about their knowledge of logic. We suggested that in order to compute a conjunctive interpretation of disjunction in the nuclear scope but not in the restrictor of 'not every', children must make use of several logical facts: (i) that the meaning of OR in natural language is inclusive-or, (ii) that 'not every' is logically equivalent to 'some not', and (iii) that disjunction gives rise to a conjunctive interpretation in the scope of a DE operator, through the application of de Morgan's law stating that 'not (P or Q)' is logically equivalent to 'not P and not Q'. As noted in the introduction, children are unlikely to be exposed to sufficient input demonstrating how the logical expressions 'not', 'every', and 'or' are interpreted in combination. Given that the requisite input is rare, we reasoned that if children are able to compute the meanings of these sentences, then it is likely that they are engaging innate knowledge of the combinatory principles of logic. So, one aim of the present study was to provide evidence bearing on the 'nature versus nurture' debate on the acquisition of logical principles.

The second aim was to test the predictions of the Semantic Subset Maxim. The Semantic Subset Maxim states the following: presented with a sentence in which two or more scope interpretations are available, if these two interpretations form a subset-superset relationship, children should initially favor the subset reading, namely the reading that makes the sentence true in the narrowest range of circumstances. Adopting this maxim ensures that children will quickly acquire the same scope preferences as adult speakers of the local language. When disjunction occurs in the nuclear scope of 'not every', a scope ambiguity of this type arises. If 'not every' is assigned wide scope over disjunction, then a conjunctive interpretation of disjunction is computed. If, on the other hand, disjunction is assigned wide scope over 'not every', then 'or' is interpreted outside of a downward entailing environment, and no conjunctive interpretation arises. The conjunctive reading is a narrower, stronger reading of the sentence than the disjunctive reading, so the SSM predicts that children should prefer the conjunctive interpretation of disjunction.

In our first test condition, the 'Nuclear Scope OR' condition, children were asked to respond to sentences like 'Not every princess took a shell or a star'. These sentences were designed to be false on a conjunctive interpretation of disjunction, but true on a disjunctive interpretation. We found that children rejected the test sentences in this condition 82% of the time. This shows that they assigned a conjunctive interpretation to disjunction, as predicted. This result supports our experimental hypothesis that children are guided by innate logical principles in their interpretation of complex logical sentences containing logical operators. In fact, we found that children preferred the conjunctive interpretation



of the test sentences more than adults did. Adults only rejected our 'Nuclear Scope OR' test sentences 68% of the time, and they accepted them 25% of the time. The acceptances were spread across 11 of the 19 adults. Although the difference between adult and child preferences in this condition was not statistically significant, it was a trend in the direction predicted by the SSM. Perhaps with a larger sample size, a significant difference would be revealed. In all, the results of the 'Nuclear Scope OR' condition strongly support Prediction 1, providing evidence that both the SSM and the relevant logical principles (outlined above) do, indeed, appear to be in operation in the language apparatus of children.

Our second test condition was the 'Restrictor OR' condition. In this condition, children responded to sentences like 'Not every girl or boy bought a ball'. Half of these sentences were true if disjunction was given a disjunctive interpretation, but false if a conjunctive interpretation was assigned. Children accepted the test sentences 65% of the time in this condition. Although above chance, children's acceptance rate was significantly different from that of adults (92% acceptance). These results, therefore, do not unequivocally support the second experimental hypothesis, Prediction 2. If children draw upon the 'not every = some not' logical equivalence in interpreting our test sentences, then they should have shown a more robust pattern of acceptances in this condition, as compared to their pattern of rejections in the 'Nuclear Scope OR' condition.

Nonetheless, this result does not necessarily mean that children were unaware that negation reverses the entailment relations of 'every', and that they thereby erroneously assigned a conjunctive interpretation to disjunction in the restrictor of 'not every', as would have been the case if children rejected the remaining trials. Children only rejected the true 'Restrictor OR' trials on 5 out of 34 trials (15% of the time). The rest of children's responses were classified as 'Other,' because children failed to clearly justify the reasons for making their judgements. This finding is indicative of a general difficulty children experienced in accepting these kinds of test sentences in the contexts provided, rather than a problem in distinguishing the arguments of 'not every'.

There are several possible reasons for this. One contributing factor might be the complex character of the downward entailing context. If we take the defining property of a DE environment to be the licensing of an inference from sets to subsets, then the nuclear scope of 'not every' clearly is downward entailing, while the restrictor is not. It is possible to make an inference from a general term to a more specific term in the nuclear scope of 'not every' (e.g., if it is true that 'not every living thing is an animal' then it is certainly true that 'not every living thing is a bird'), while it is not in the restrictor (e.g., if it is true that 'not every animal has four legs', then it is not necessarily true that 'not every fox has four legs'). In this study we concentrated on one of the diagnostic properties of DE contexts, the conjunctive interpretation of disjunction, which arises in the nuclear scope of 'not every' and not in the restrictor. However, as we discussed in the introduction, another diagnostic property is the licensing of NPI items like 'any'. In fact, it turns out that 'any' is NOT licensed in the nuclear scope of 'not every', while it is licensed in the restrictor. Compare (30a) and (b).

- (30) a. \*Not every girl or boy bought any ball.  
 b. Not every girl or boy who had any money bought a ball.

The ungrammaticality of (30a), as opposed to (30b), shows that being in the scope of a DE operator is not necessarily a sufficient condition to license an NPI like ‘any’. When certain logical operators intervene between a DE operator and an NPI, the patterns of licensing can be disrupted. In (30), it seems that the intervention of the universal quantifier ‘every’ between ‘not’ and ‘any’ blocks the negation operator from licensing ‘any’ in the predicate phrase. On the other hand, ‘any’ is grammatical in the subject phrase, because it is in the scope of the DE operator ‘every’ in that structural position.

Intervention effects in NPI licensing have been the subject of much investigation (see for example: Chierchia 2004, Chierchia *et al.* 2011, Guerzoni 2006, Linebarger 1987), however a discussion of these effects would take us beyond the concerns of the present paper. All we wish to point out is that, due to these effects, the DE properties of the complex quantifier ‘not every’ present a mixed picture to children. On the one hand, the conjunctive interpretation arises in the nuclear scope, but not in the restrictor. On the other hand, an NPI item like ‘any’ is not licensed in the nuclear scope, but is licensed in the restrictor. Perhaps this conflicting combination of diagnostic properties contributed to children’s difficulty with our ‘Restrictor OR’ trials. Nonetheless, if this were the reason for children’s difficulty, it is strange that it did not appear to affect children’s ability to respond to the ‘Nuclear Scope OR’ trials. Our guess is, rather, that children’s difficulty stemmed from a pragmatic infelicity in the construction of our trials. This would mean that in a more felicitous context, it should be possible to show that children accept true ‘Restrictor OR’ trials to a higher degree. This in turn would show that the logical principles under investigation are, indeed, applied by children in all the required semantic environments.

One source of possible infelicity in our ‘Restrictor OR’ trials is the fact that we used a negative statement, rather than a positive one, to describe the situation at the end of each story. It has been shown that two approaches can help in mitigating this infelicity. One approach recommends the use of a positive lead-in statement (Musolino & Lidz 2006), which is the tactic we employed. Another approach recommends introducing an explicit discrepancy between the expected and actual outcome of each story (Gualmini 2005). We wondered whether combining these two approaches might be required to help children accept complex negative statements like those tested in the ‘Restrictor OR’ condition. We adapted our true ‘Restrictor OR’ stories to set up a clear discrepancy between the expected and actual outcome. For example, in our toyshop story, we mentioned that the balls for sale in the shop cost three coins, and the books only cost two coins. Every child who visited the shop wanted to buy a ball, but only two boys and one girl had enough money to do so. The last little girl only had two coins, because she had spent one on the way to the shop, and so she had to buy a book. This set-up emphasized that all the children were expected to buy balls, but in actual fact, one could not. The puppet then uttered the test sentence with a positive lead-in as in the original study (e.g., ‘every child bought something, and I know: Not every girl or boy bought a ball’). We piloted these

new stories with 5 children (aged 3;9–5;1). The children heard two stories each. However, we found almost identical results to the ones reported here. The children accepted the stories 66% of the time, and rejected them 33% of the time. We take from this that our original positive lead-ins were already sufficient to counter any infelicity associated with the use of a negative statement to describe the situations under consideration. Indeed, this makes sense given that the children were perfectly able to accept our true control statements (e.g., not every pirate caught a horse) with a positive lead-in alone.

Another more promising possibility is that our stories did not satisfy one of the presuppositions that is associated with the use of a universally quantified phrase that contains disjunction in the restrictor. Consider a phrase like 'every passenger who ordered chicken or beef'. It is only useful to divide the superset of passengers into two subsets if we are then contrasting these two subsets with one or more other subsets. For example, we might want to say 'every passenger who ordered chicken or beef became ill, but passengers who ordered fish did not'. If there are only passengers who ordered chicken or beef in the context, and they all fell ill, then it is pragmatically odd to state this. One might as well say 'Every passenger became ill'. Using disjunction in the restrictor of a universally quantified phrase therefore presupposes that there is at least one other subset in the context that doesn't share the property attributed to the two subsets being quantified over. To satisfy this presupposition, we would need to include a contrast set of characters in our stories, in addition to the two sets of characters being universally quantified over. We leave this modification for a future study.

Despite inconclusive results in our 'Restrictor OR' condition, our 'Nuclear Scope OR' condition has allowed us to further test both the predictions of the Semantic Subset Maxim, and the hypothesis that children possess a body of logical knowledge that initially guides them in their interpretation of sentences containing logical operators. We have shown that English-speaking children access the conjunctive interpretation of disjunction in the nuclear scope of 'not every', a compound quantifier that had not yet been investigated in the literature. In fact, they access this interpretation more often than adults, which is in line with the predictions of the Semantic Subset Maxim. We have further suggested that children are capable of correctly interpreting these complex sentences because they are guided by a set of logical principles which together result in OR being assigned a conjunctive interpretation whenever it occurs in a downward entailing environment in natural language.

## **Appendix: Test Materials**

### ***A.1. Testing Session 1***

Warm-Up: I know what happened to Piglet. Piglet ate the (thing he ate) [T]

Warm-Up: Let me see, Eeyore ate the (1st thing he ate) [T], and he didn't eat the (2nd thing he ate) [F].

Control: That was a story about 4 pirates trying to catch animals and I know

- Not every pirate caught a dinosaur [F]
- Control: Let me try something else. Not every pirate caught a horse [T]
- Filler: I know what the first pirate did. Catch a horse and an orange dinosaur is what the first pirate did [F]
- Test 1: That was a story about 4 farmers washing animals. Every farmer washed some animals and I know — Not every farmer washed a cow or a dog [F]
- Filler: I know what the pigs did. What the pigs did is get out of their pond [F]
- Test 2: That was a story about 4 babies and their parents, the mums and dads. Every parent came to check on the babies and I know — Not every mum or dad put a baby to bed [F]
- Filler: I know what the last dad did. Choose a yellow blanket is what the last dad did [T]
- Test 3: That was a story about 4 frogs playing a jumping game. Every frog jumped over something and I know — Not every frog jumped over the fence or the pond [F]
- Filler: I know what Mrs. Kangaroo did. What Mrs. Kangaroo did is jump over all the frogs [F]
- Test 4: That was a story about some fish and some dolphins at school learning about shapes. Every animal swam through a shape, and I know — Not every fish or dolphin swam through a square [T]
- Filler: The first little fish swam through a blue square [T]

### A.2. *Testing Session 2*

- Control: That was a story about 4 aliens trying new things to eat. Every alien had something to eat, and I know — Not every alien tried a strawberry [F]
- Control: Let me try something else. Not every alien tried a feather [T]
- Filler: Some of the aliens tried the red feathers, and none of the aliens tried the purple feather [T]
- Test 5: That was a story about Mrs. Mouse's toyshop and the girls and boys who came to the shop. Every child bought something and I know — Not every girl or boy bought a ball [T]
- Filler: I know what the last little girl did. Buy a blue book is what the last little girl did [T]
- Test 6: That was a story about 4 princesses looking for treasure. Every princess took some treasure and I know — Not every princess took a shell or a star [F]
- Filler: I know what the first princess did. What the first princess did is take a star and a purple shell [T]
- Test 7: That was a story about some caterpillars and some crocodiles in a maze. Every animal reached the end of the maze and got a prize, and I know — Not every caterpillar or crocodile chose a yo-yo [F]
- Filler: I know what the last crocodile did. Choose a red yo-yo is what the last crocodile did [F]

- Test 8: That was a story about 4 trolls who liked to tickle animals. Every troll tickled somebody and I know — Not every troll tickled a turtle or a teddy [F]
- Filler: I know what the bunnies did. What the bunnies did is hop so fast the trolls couldn't catch them [T]

## References

- Atlas, Jay D. & Stephen C. Levinson. 1981. It-clefts, informativeness, and logical form: Radical pragmatics (revised standard edition). In Peter Cole (ed.), *Radical Pragmatics*, 1–62. New York: Academic Press.
- Berwick, Robert. 1985. *Acquisition of Syntactic Knowledge*. Cambridge, MA & London: MIT Press.
- Boster, Carole T. & Stephen Crain. 1993. On children's understanding of Every and Or *Conference Proceedings: Early Cognition and the Transition to Language*. Austin, TX: University of Texas.
- Brown, Roger. 1973. *A First Language: The Early Stages*. Cambridge, MA: Harvard University Press.
- Chierchia, Gennaro. 2004. Scalar implicatures, polarity phenomena and the syntax/pragmatics interface. In Adriana Belletti (ed.), *Structures and Beyond: The Cartography of Syntactic Structures*, vol. 3, 39–103. Oxford: Oxford University Press.
- Chierchia, Gennaro, Stephen Crain, Maria T. Guasti, Andrea Gualmini & Luisa Meroni. 2001. The acquisition of disjunction: Evidence for a grammatical view of scalar implicatures. In Anna H.-J. Do, Laura Domínguez & Aimee Johansen (eds.), *BUCLD 25 Proceedings*, 157–168. Somerville MA: Cascadia Press.
- Chierchia, Gennaro, Danny Fox & Benjamin Spector. 2011. The grammatical view of scalar implicatures and the relationship between semantics and pragmatics. In Claudia Maienborn, Klaus von Stechow & Paul Portner (eds.), *Semantics: An International Handbook of Natural Language Meaning*, vol. 3. Boston, MA & Berlin: Walter de Gruyter.
- Chierchia, Gennaro, Maria T. Guasti, Andrea Gualmini, Luisa Meroni, Stephen Crain & Francesca Foppolo. 2004. Semantic and pragmatic competence in children's and adults' comprehension of or. In Ira A. Noveck & Dan Sperber (eds.), *Experimental Pragmatics*, 283–300. Basingstoke: Palgrave Macmillan.
- Crain, Stephen, Amanda Gardner, Andrea Gualmini & Beth Rabbin. 2002. Children's command of negation. In Yukio Otsu (ed.), *Proceedings of the 3rd Tokyo Conference on Psycholinguistics*, 71–95. Tokyo: Hituzi Publishing.
- Crain, Stephen, Takuya Goro & Rosalind Thornton. 2006. Language acquisition is language change. *Journal of Psycholinguistic Research* 35, 31–29.
- Crain, Stephen, Andrea Gualmini & Luisa Meroni. 2000. The acquisition of

- logical words. *LOGOS and Language* 1, 49–59.
- Crain, Stephen, Andrea Gualmini & Paul Pietroski. 2005. Brass tacks in linguistic theory: Innate grammatical principles. In Peter Carruthers, Stephen Laurence & Stephen Stich (eds.), *The Innate Mind: Structure and Contents*, 175–197. Oxford: Oxford University Press.
- Crain, Stephen & Drew Khlentzos. 2008. Is logic innate? *Biolinguistics* 2, 24–56.
- Crain, Stephen & Drew Khlentzos. 2010. The logic instinct. *Mind & Language* 25, 30–65.
- Crain, Stephen, Weijia Ni & Laura Conway. 1994. Learning, parsing, and modularity. In Charles Clifton Jr., Lyn Frazier & Keith Rayner (eds.), *Perspectives on Sentence Processing*, 443–467. Hillsdale, NJ: Lawrence Erlbaum.
- Crain, Stephen & Rosalind Thornton. 2006. Acquisition of syntax and semantics. In Matthew J. Traxler & Morton A. Gernsbacher (eds.), *Handbook of Psycholinguistics* (2nd edn.), 1073–1110. Amsterdam: Elsevier.
- Crain, Stephen, Rosalind Thornton, Carole Boster, Laura Conway, Diane Lillo-Martin & Elaine Woodams. 1996. Quantification without qualification. *Language Acquisition* 5, 83–153.
- Freeman, Norman H., Chris G. Sinha & Jackie A. Stedmon. 1982. All the cars — which cars? From word meaning to discourse analysis. In Michael Beveridge (ed.), *Children Thinking Through Language*, 52–74. London: Edward Arnold.
- Goro, Takuya & Sachie Akiba. 2004a. The acquisition of disjunction and positive polarity in Japanese. In Vineeta Chand, Ann Kelleher, Angelo J. Rodriguez & Benjamin Schmeiser (eds.), *WCCFL 23 Proceedings*, 251–264. Somerville, MA: Cascadilla Press.
- Goro, Takuya & Sachie Akiba. 2004b. Japanese disjunction and the acquisition of positive polarity. In Yukio Otsu (ed.), *Proceedings of the 5th Tokyo Conference on Psycholinguistics*, 137–162. Tokyo: Hituzi Shobo.
- Grice, Paul H. 1975. Logic and conversation. In Peter Cole & Jerry L. Morgan (eds.), *Speech Acts*. New York: Academic Press.
- Gualmini, Andrea. 2005. *The Ups and Downs of Child Language: Experimental Studies on Children's Knowledge of Entailment Relationships and Polarity Phenomena*. New York & London: Routledge.
- Gualmini, Andrea & Stephen Crain. 2002. Why no child or adult must learn de Morgan's laws. In Barbara Skarabela, Sarah Fish & Anna H.-J. Do (eds.), *BUCLD 26 Proceedings*, 243–254. Somerville, MA: Cascadilla Press.
- Gualmini, Andrea & Stephen Crain. 2005. The structure of children's linguistic knowledge. *Linguistic Inquiry* 36, 463–474.
- Gualmini, Andrea, Stephen Crain & Luisa Meroni. 2000. Acquisition of disjunction in conditional sentences. In S. Catherine Howell, Sarah A. Fish & Thea Keith-Lucas (eds.), *BUCLD 24 Proceedings*, vol. 1, 367–378. Somerville, MA: Cascadilla Press.
- Gualmini, Andrea, Luisa Meroni & Stephen Crain. 2003. An asymmetric universal in child language. In Matthias Weisgerber (ed.), *Proceedings of the Conference "sub7 — Sinn und Bedeutung"*, vol. 114, 136–148. Konstanz, Germany: Fachbereich Sprachwissenschaft der Universität Konstanz.
- Guerzoni, Elena. 2006. Intervention effects on NPIs and feature movement: Towards

- a unified account of intervention. *Natural Language Semantics* 14, 359–398.
- Heim, Irene. 1988. *The Semantics of Definite and Indefinite Noun Phrases*. New York: Garland.
- Horn, Laurence R. 1996. Presupposition and implicature. In Shalom Lappin (ed.), *The Handbook of Contemporary Semantic Theory*, 299–319. Cambridge, MA & Oxford: Blackwell.
- Linebarger, Marcia. 1987. Negative polarity and grammatical representation. *Linguistics and Philosophy* 10, 325–387.
- McWhinney, Brian. 2000. *The CHILDES Project: Tools for Analyzing Talk*. Mahwah, NJ: Lawrence Erlbaum.
- Meroni, Luisa, Stephen Crain & Andrea Gualmini. 2001. Felicity conditions and on-line interpretation of sentences with quantified NPs. Paper presented at the 14th Annual CUNY Conference on Human Sentence Processing, Philadelphia: University of Pennsylvania.
- de Morgan, Augustus. 1966. *On the Syllogism And Other Logical Writings*, Peter Heath (ed.), London: Routledge and Kegan Paul.
- Morris, Bradley J. 2008. Logically speaking: Evidence for item-based acquisition of the connectives AND & OR. *Journal of Cognition and Development* 9, 67–88.
- Musolino, Julien & Jeffrey Lidz. 2006. Why children aren't universally successful with quantification. *Linguistics* 44, 817–852.
- Notley, Anna, Peng Zhou, Britta Jensen & Stephen Crain. 2011. Children's interpretation of disjunction in the scope of 'before': A comparison of English and Mandarin. *Journal of Child Language*.
- O'Leary, Carrie. 1994. Children's Awareness of Polarity Sensitivity. MA Thesis, University of Connecticut.
- Pinker, Stephen. 1984. *Language Learnability and Language Development*. Cambridge, MA: Harvard University Press.
- Su, Esther & Stephen Crain. 2009. Disjunction and universal quantification in child Mandarin. In Yukio Otsu (ed.), *The Proceedings of the Tenth Tokyo Conference on Psycholinguistics*. Tokyo, Japan: Hituzi Syobo Publishing.
- Szabolcsi, Anna. 2002. Hungarian disjunctions and positive polarity. In Istvan Kenesei & Peter Siptar (eds.), *Approaches to Hungarian* 8, vol. 8, 217–241. Budapest: Akademiai Kiado.
- Tieu, Lyn S. 2010. On the tri-ambiguous status of *any*: The view from child language. In Nan Li & David Lutz (eds.), *Proceedings of SALT 20*, 19–37.
- van der Wal, Sjoukje. 1996. Negative polarity items and negation: tandem acquisition. *Groningen Dissertation in Linguistics* 17.

Anna Notley<sup>1</sup>, Rosalind Thornton<sup>2</sup>, and Stephen Crain<sup>3</sup>  
 Macquarie University  
 ARC Centre of Excellence in Cognition and its Disorders  
 Department of Cognitive Science<sup>1</sup> and Department of Linguistics<sup>2,3</sup>  
 NSW 2109  
 Australia

<sup>1</sup>[anna.notley@mq.edu.au](mailto:anna.notley@mq.edu.au), <sup>2</sup>[rosalind.thornton@mq.edu.au](mailto:rosalind.thornton@mq.edu.au), and <sup>3</sup>[stephen.crain@mq.edu.au](mailto:stephen.crain@mq.edu.au)

## All Tied in Knots

David J. Lobina

In this note, I wish to critique a proposal put forward by Camps & Uriagereka (2006; C&U) and Balari *et al.* (2011; BEA) regarding the study of the evolution of language. In particular, I intend to cast doubt on the connection they draw between the computational properties of the language faculty and those involved in the conceptualization of a knot. In what follows, I will offer a rather negative commentary, in the sense that no alternative will be forthcoming. In fact, one of the main points of this paper will be that there is no phenomenon to explain at all; or at least it has not been properly formulated.

The general idea underlying what C&U and BEA propose is clear enough. Considering that the language faculty is underlain by a computational system that generates sound/meaning pairs, it ought to be possible to outline some of its computational properties. Furthermore, it is at least a possibility for some other cognitive domain of the human mind to share some of these very computational properties. If that is the case, C&M claim, such a domain would constitute a “cognitive base” that can be said to be in a “causal correlation” with the linguistic capacity (p. 35) — that is, the computational properties of such a ‘base’ would be parasitic on those of the language faculty. If this holds, the behaviors associated with this cognitive base could plausibly constitute indirect evidence for an “underlying linguistic prerequisite” (*ibid.*).

I pretty much doubt that such an inference is in fact sound, but let it stand for the sake of the argument. The specific behavior that engages C&U and BEA relates to the ability to tie a knot, a skill that must have originated in modern man, given that evidence for it in the fossil record — such as in the binding of projectiles to their shafts (C&U: 58) — is only present in the archaeology of *Homo Sapiens* (p. 45). Naturally, language and knot-tying are phenomena that at first sight appear to be completely unrelated, but C&U and BEA assure us that they may in fact share underlying properties. The overall argument is more or less as follows. According to mathematical linguistics, the expressive power of natural language is context-sensitive (or more accurately, mildly context-sensitive; Joshi *et al.* 1990); thus the computational system underlying language is of such power. Further, the mathematical structure of knots may be studied by employing the tools of Knot Theory, a subfield of mathematical topology. According to C&U, and citing a work from this literature (*viz.* Mount 1989), knots can only be created / described by a context-sensitive system, a conclusion they take to be “not subject to rational debate” (p. 63). In a related manner, BEA conclude, citing another

---

I am grateful to Mark Brenchley, José E. García-Albea, Aravind Joshi, and Mario Santos-Sousa for helpful comments on a longer version of this paper. Part of this research was funded by an AGAUR grant 2009 SGR-401 awarded by the Catalan administration.





study from Knot Theory (Hass *et al.* 1999), that determining whether a string is knotted or not is of a computational complexity comparable to the processing of linguistic expressions (p. 11). Given that evolution doesn't, apparently, generate identical structures (C&U: 45), the ability to entertain and create knots may indeed be parasitic on computational properties of the language faculty.

Note, first of all, that in the above paragraph there is a leap from the expressive power of a language to the computational complexity of processing it; whilst these two factors are closely related, they should not be conflated. Such computational properties point, of course, to the classification of formal grammars and languages that Chomsky (1956, 1963) delineated — the so-called Chomsky Hierarchy.<sup>1</sup> In those publications, Chomsky ranked different classes of formal languages (where a language is defined as a set of strings of symbols) in terms of the formal grammars (i.e. string rewriting systems) that are said to *generate* these languages. The expressive power of a grammar, then, refers to the precise set of strings that it can generate. Moreover, to say that a grammar is context-sensitive is to specify a particular set of constraints on the form of its rewriting rules that differentiates them from, for example, a context-free grammar. Concurrently, mathematical linguistics has also focused on the automata that are said to *recognize* each of the languages of the Chomsky Hierarchy (Hopcroft *et al.* 2007). In particular, it has been amply demonstrated that for each language class there is an automaton that recognizes all sets of strings of this class; in this sense, each grammar is equivalent to a specific automaton. In a perhaps more neutral vocabulary, one could state that automata and grammars *specify* languages.

Even though both automata and grammars describe the same reality — *viz.* a ranking of different language classes — there is a clear difference in perspective between employing a grammar and an automata in the study of computational properties.<sup>2</sup> Indeed, it is no surprise that it is the latter construct that has featured more extensively in the study of the “rate of growth of the time or space” required to solve a problem (Aho *et al.* 1974: 2); that is, the study of the computational complexity of a problem is much more amenable for study by employing abstract machine devices such as automata than it is with a grammatical

---

<sup>1</sup> It seems to me that this leap and the subsequent conflation of these two properties stems from the manner in which C&U and BEA interpret the Chomsky Hierarchy. In fact, these two publications follow the (in my opinion entirely misbegotten) ‘re-interpretation’ of the Chomsky Hierarchy Uriagereka conducts in chapter 7 of his 2008 book. This is rather surprising, for a number of reasons. First of all, even though C&U (p. 36) state that their description of the Hierarchy is based on Uriagereka (2008) — which they define, rather conceitedly, as a “current linguistic perspective” — this book was not even published at the time. More importantly, Uriagereka himself would surely admit that his re-interpretation is not only non-standard, but a very speculative exercise indeed. Why would these scholars, then, assume its validity as a framework upon which to draw a comparison between language and knot-tying? Be that as it may, the main mistake of this re-interpretation lies in Uriagereka’s belief that focusing on the different automata that specify the different language classes gives you an account of structure generation, but this is quite simply not true; see *infra* for more details.

<sup>2</sup> Hopcroft & Ullman (1969: 5) call these two perspectives the “recognition point of view” and the “generative point of view”. Similarly, Wintner (2010: 17) talks of the “dual view of language”.

formalism.<sup>3</sup> If this is so, it is the case that the preoccupations of Automata Theory revolve (mainly) around discovering the inherent computational difficulty of various problems.

Consequently, when it is stated that natural language has a particular computational complexity, this is supposed to refer to the inherent difficulty involved in processing linguistic structures. As it happens, what computational complexity is in fact involved in the processing of language is very uncertain. In a review article explicitly devoted to this question, and even though one of its sections is titled “Parsing and recognition”, Pratt-Hartmann (2010) focuses his attention on a much narrower issue: the recognition problem. That is, given a grammar  $G$  within a specific formalism  $F$ , the recognition problem aims to ascertain the amount of time and space that a Turing Machine would require in order to determine if a given string defined over the alphabet of  $G$  belongs to the language specified by  $G$  (Pratt-Hartmann 2010: 55). According to Pratt-Hartmann, the computational complexity of a grammar can only be determined within a specific formalism, and therefore different formalisms are likely to involve different measures of complexity. For example, the recognition of a context-free grammar specified in Chomsky normal form (see *infra*) can be achieved by the so-called CYK algorithm in time  $O(mn^3)$ , where  $m$  is the number of production rules,  $n$  is the length of the string, and  $O$  refers to the upper bound on the growth rate of this specific function (pp. 57–58). In other formalisms, the measures of complexity differ considerably: For a language represented with a *tree adjoining grammar* (TAG; see Frank 2004 for a brief description),<sup>4</sup> the recognition problem can be solved in time  $O(n)$ <sup>6</sup> (p. 60); with a *government and binding* formalism, the problem is in the class PSPACE<sup>5</sup>; and, finally, in the case of an *Aspects*-based grammar, the recognition problem is quite simply undecidable (p. 63).

At first sight, these results would appear to be far removed from the interests of a psycholinguist, and in a sense, they clearly are. After all, language processing is not at all like the problem of determining whether a string is part of a language (putting aside the ability to judge the grammaticality of sentences to one side, obviously). That this is so follows, in my opinion, from the rather incontrovertible fact that formal language theory, strictly speaking, focuses on the properties of sets of strings of symbols, and not, or at least not as much, on the structural descriptions that are assigned to these strings. The issues at hand, however, are rather subtle and significant care must be employed in their discussion.

Consider a grammar formalized in (a simplified version of) Chomsky normal form; namely, a 3-tuple composed of a set of non-terminals, a set of terminals and a set of production rules. Assume that there is a ‘start’ symbol that can be expanded by employing one of the production (that is, rewriting) rules of the grammar. In turn, the resultant string — a composition of terminal and non-

<sup>3</sup> Cf. Aho *et al.* (1974: iii): “[T]o analyze the performance of an algorithm some model of a computer is necessary”. Similarly, Pratt-Hartmann (2010) employs a multi-tape Turing Machine in order to summarize the main results of studies in computational complexity.

<sup>4</sup> Incidentally, the expressive power of TAG is mildly context-sensitive, which is argued to be the correct expressive power of natural language.

<sup>5</sup> For a problem to be in the class PSPACE means that the Turing Machine would require a polynomial amount of space to solve the recognition problem.

terminal symbols — can be further expanded by using other rewriting rules until a string consisting only of terminals is derived. The history of these rule applications is usually called a derivation, and it is possible to use a tree representation as a visual aid in order to depict a given derivation in graphic form. In this sense, the ‘derivation tree’ so devised would specify the structure of the string so generated.

Note, however, that there are in fact two structural descriptions at hand here, what Simon (1962) called a state description (an object as sensed) and a process description (an object as is constructed), respectively. While obviously related (a process generates an object), the internal structure of each construct may not coincide piecemeal. Perhaps it is the case that there is a direct connection between the applications of rewriting rules and the intrinsic structure of a linguistic object so generated — surely the devise of linguists —, but such a nexus is not quite so transparent in other formalisms. As Miller (1999) points out, there is a difference between a ‘derived tree’ and a ‘derivation tree’ in TAG; whilst the former describes a linguistic object as postulated by the linguist (as in the syntactic trees so common in many a linguistic paper), the latter specifies the operations that TAG employs (viz. the adjunction and substitution of ‘elementary trees’). Further, Miller (1999) proceeds, it is to the latter than we ought to focus if we are interested in the structures that TAG generates (usually called its strong generative capacity).<sup>6</sup> That is, it is the derivation tree that specifies the structural descriptions of a formalism, not the derived tree.

My present point is that there is a difference between a string rewriting system as employed in mathematical linguistics and a tree rewriting system such as TAG in respect to what products these two systems return (cf. Miller 1999: 29). Strictly speaking, the rewriting systems of formal language theory generate strings (weak generation); they don’t generate structures. That is, there is nothing in the formalism of a rewriting system itself that even hints at the possibility of generating structure. Certainly, it is possible to modify such systems so that they generate structures, and this is precisely what obtains in systems such as those employed in a TAG. In my view, then, it is entirely correct to state that a rewrite rule generates a string to which a structural description is associated (surely an assignment that the linguist carries out; cf., again, Miller 1999: 2), but it is simply fantasy to suppose that they literally generate structures.

The same point applies to automata, which for present purposes can be described, in a somewhat simplifying manner, as being composed of an input tape, a control operation and a finite set of states (such as the initial state and the final, accepting state; Hopcroft *et al.* 2007: 45–46). It is certainly true that a properly characterized automaton would be able to accept a string of symbols of which we predicate a structure, but the automaton itself would not reflect in any way the internal constitution the set of symbols it receives is supposed to underlie. To suppose otherwise, it would quite simply be a figment of someone’s imagination; or worse, metaphor.<sup>7</sup>

<sup>6</sup> Stabler (forthcoming) makes the very same point regarding the merge-based derivations of his minimalist grammars.

<sup>7</sup> Hopcroft *et al.* (2007: 243–244) point out that a pushdown automaton (the automaton that specifies/recognizes context-free languages) can simulate the derivations of a grammar, in

Consequently, even if mathematical linguistics may have been able to study the computational complexity exemplified in various automata or grammatical formalisms to a significant extent, none of this may bear any resemblance to what goes on in the mind of speakers and hearers when they produce or process linguistic material. Admittedly, a hearer receives a chain of elements in a temporal sequence, but it is rather obvious that this input is not treated as if it were a string of symbols; rather, a structure is imposed on this material in some manner. Accordingly, the computational complexity of natural language processing will have to consider properties of human psychology such as memory limitations, the strategies that are employed in parsing, the use of the immediate context and many other factors. All in all, it is simply not known what computational complexity our mental machinery exhibits in the processing of language. Consequently, a comparison with other computational tasks in these very terms seems to me rather flimsy.

Even if this weren't the case, it is very easy to show that the mathematical theory of knots is in fact not informative about either the expressive power or the computational complexity involved in tying a knot. Further, it also has nothing to say regarding how to determine if a string is knotted. This is unquestionable the case because the subject matter of such a field involves something else altogether. *A fortiori*, no relation can at present be drawn between the ability to tie a knot and the conceptualization/processing of language.

As in any other subfield of mathematics, Knot Theory is a rather narrow and technical discipline, a factor that should make anyone skeptical of the possibility of adapting it to the purposes of studying human cognition. As it turns out, the knots that Knot Theory studies bear no relation to real knots. Basically, a mathematical knot is a closed structure, an embedding of a circle into Euclidean 3-space (Burde & Zieschang 2003: 1). Moreover, the main line of research in this field is extremely narrow; what these theorists attempt to do is figure out which two knots are isotopic and which are not, where two knots are regarded as isotopic if one of them can be transformed into the other by following step-by-step moves. This, the knot recognition problem, involves working out the formal equivalence of two knots. A special case of this problem concerns the so-called 'unknot', a closed loop without any knot in it, as shown on the left-hand side of Figure 1 below. The 'unknotting' problem, in turn, involves specifying an algorithm that can recognize the unknot in a figure like the one found on the right-hand side of Figure 1 (that is, convert the knot on the right-hand side into an unknot).

---

the sense that the material the automaton is inputted can be manipulated in a manner that mimics the rule applications of the grammar (that is, the derivation). The same point follows: the structure that is assigned to the derivation (by the linguist) plays no role in the operations of such formalisms. Furthermore, the structure of a given derivation may not coincide with the structure of the object that is constructed. After all, simulation and mimicking do not stand on the same ground as a mechanism that is literally constructed as to generate structures, such as a tree rewriting system or an embedding mechanism like Merge (this situation is a bit like the attempt to model language comprehension — or indeed the whole of cognition — as a type of Bayesian inference; virtually anything can be so modeled, but this doesn't imply that mental mechanisms in fact effect such inferences).

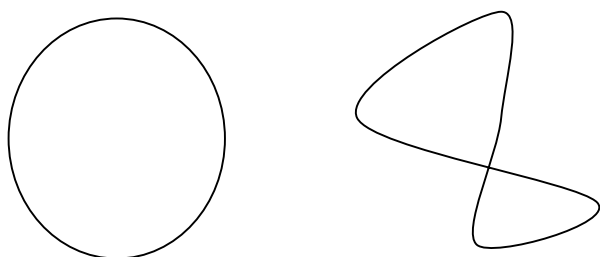

Figure 1: The unknot and a non-trivial knot

Relevant to the issues I am unearthing here is the so-called Reidemeister moves, a set of well-defined combinatorial moves that can disentangle a knot without damaging it (note that these moves *disentangle* a knot, they don't untie it). There are three such moves: twist/untwist; move one strand over another; and move one strand over/under a crossing (Manturov 2004: 12).

Naturally, none of this has anything to do with how you go about tying a knot, let alone the computational complexity required to do so. Perhaps unsurprisingly, the actual details of Knot Theory go completely unmentioned in C&U; its relevance to real-life knot-tying abilities just assumed. BEA do point out that Knot Theory deals with “elastic, closed, and tangled knots” (p. 11), but they go on to claim that “formal details aside” (as if they were of no importance), “the task of determining whether any string is knotted is known to have a complexity comparable to the one needed to process linguistic expressions” (*ibid.*; reference: Hass *et al.* 1999). And a bit later, they say, “(un)tying knots (or determining whether a tangled string is knotted) seems to require an underlying computational system of Type 1” (*ibid.*; Type 1 in the CH: context-sensitive).

There are two things at fault here. First is the claim that Knot Theory involves “determining whether a string is knotted”, something that is clearly *not* the case, as Knot Theory takes tied knots as its starting assumptions — indeed, this field's sole concern is the equivalence problem outlined above. The other problem is to treat (un)tying a knot and determining if a string is knotted as if they are equivalent, but there are no reasons whatsoever to believe so. Furthermore, the reference BEA include in relation to this (*viz.* Hass *et al.* 1999) is clearly misrepresented. Rather, what Hass *et al.* (1999) proved is that an algorithmic solution for the unknotting problem is in the complexity class NP, which is to say that the algorithm will define multiple ways of processing the input without specifying which one it will take, in polynomial time. Quite clearly, this has *no* relation to either the mildly context-sensitive expressive power of language or the complexity involved in language processing; moreover, it also has *no* relation to the complexity of (un)tying a knot.

Nevertheless, this is not to say that (un)tying a knot may well involve a non-trivial computational system, but we don't have an account of this.<sup>8</sup> At one point, BEA do envision what may actually be involved in making a knot; one must relate, they tell us, a segment of the knot with the background, and this may

<sup>8</sup> In this and the next paragraph, I implicitly assume that knot tying can be modeled as a computational task, but I do not actually think this is so obvious. In any case, it would have to be demonstrated, not presumed.

well involve “grouping and long-distance-like relations” (p. 11). This insight comes from C&U, in fact; therein, the authors briefly describe a possible transformation of a string into a knot by assigning a specific number to each segment so that these symbols can in turn be manipulated by a (context-sensitive) grammar. They don’t provide a proof of this, but the underlying idea is not incoherent. For example, Turing (1954) discusses a similar issue in relation to solvable and unsolvable problems in Knot Theory. As noted earlier, a knot is a closed curve in three dimensions, but it can also be accurately described, Turing tells us, “as a series of segments joining the points given in the usual (x, y, z) system of coordinates” (p. 585). Further, a set of symbols can be employed to represent unit steps in each coordinate direction (say, *a*’s and *d*’s for the X-axis, and so forth) so that transformation moves can be modeled by substitution rules of the production systems variety.

These are, in fact, the terms in which I assume C&U claimed that Mount (1989) showed the necessity of a context-sensitive system to create knots; a conclusion, it will be recalled, supposedly “not subject to rational debate”. Somewhat amusingly, Mount (1989) turns out to be an unpublished computer manual for a program devised to assist mathematicians in the study of Knot Theory. At one point (p. 4), this author discusses the Reidemeister moves I outlined above, and remarks that the transformation of one knot into another may be reduced to a grammar problem, in precisely the terms Turing (1954) discusses. Later on, it is again remarked that “the Reidemeister moves could be rephrased as some kind of context-sensitive grammar” (p. 5).

Note what is actually being claimed here. First, that the Reidemeister moves *could* be modeled by a context-sensitive grammar; obviously, this is not a demonstration, but mere supposition. Secondly, such a supposition is exclusively meant to relate to the (narrow) purposes of Knot Theory; that is, Mount is wondering whether a production system may be employed to study the knot recognition problem. Again, this has nothing to do with the computational complexity or expressive power of (un)tying a knot in real life. Nor could it be construed as even suggesting such a connection. It is rather astonishing that the passing comments of an unpublished computer manual can become, on anyone’s reading, a conclusion “not subject to rational debate”.

In short, as it stands there is no fact of the matter regarding what relation there is, if there must be one, between the computational properties of the language faculty and whatever capacity underlies our ability to conceptualize and indeed tie a knot. This is not to say that there might not be a fruitful way to study such a relationship, but neither C&U nor BEA have provided any reason whatsoever, plausible or speculative, to believe that there is anything in need of explanation here.

In order to put an end to this brief examination, I should also add that C&U and BEA raise many other issues that are certainly worth discussing, such as the application of the Chomsky Hierarchy in the study of cognitive domains, the role of the different levels of analysis in such a study, and general features of mental architecture. In my opinion, there are significant shortcomings in the manner in which they treat all these issues, but this is not the place to discuss any of this; I do note, however, that I have done so elsewhere (Lobina 2012).

## References

- Aho, Alfred V., John E. Hopcroft & Jeffrey D. Ullman. 1974. *The Design and Analysis of Computer Algorithms*. London: Addison-Wesley Publishing Company.
- Balari, Sergio, Antonio Benítez-Burraco, Marta Camps, Víctor M. Longa, Guillermo Lorenzo & Juan Uriagereka. 2011. The archaeological record speaks: Bridging anthropology and linguistics. *International Journal of Evolutionary Biology* 2011, doi:10.4061/2011/382679.
- Burde, Gerhard & Heiner Zieschang. 2003. *Knots*. Berlin: Walter de Gruyter.
- Camps, Marta & Juan Uriagereka. 2006. The Gordian knot of linguistic fossils. In Joana Rosselló & Jesús Martín (eds.), *The Biolinguistic Turn. Issues on Language and Biology*, 34–65. Barcelona: Publications of the University of Barcelona.
- Chomsky, Noam. 1956. Three models for the description of language. *IRE Transactions of Information Theory IT-2*, 113–124.
- Chomsky, Noam. 1963. Formal properties of grammars. In R. Duncan Luce, Robert R. Bush & Eugene Galanter (eds.), *Handbook of Mathematical Psychology*, vol. 2, 323–418. New York, NY: John Wiley.
- Frank, Robert 2004. Restricting grammatical complexity. *Cognitive Science* 28, 669–697.
- Hass, Joel, Jeffrey C. Lagarias & Nicholas Pippenger. 1999. The computational complexity of knot and link problems. *Journal of the ACM* 46, 185–211.
- Hopcroft, John E. & Jeffrey D. Ullman. 1969. *Formal languages and their Relation to Automata*. London: Addison-Wesley Publishing Company.
- Hopcroft, John E., Rajeev Motwani & Jeffrey D. Ullman. 2007. *Introduction to Automata Theory, Languages and Computation*. London: Addison-Wesley.
- Joshi, Aravind K., K. Vijay Shanker & David Weir. 1990. The convergence of mildly context-sensitive formalisms. Department of Computer and Information Science Technical Report (University of Pennsylvania), 1–65.
- Lobina, David. 2012. Conceptual structure and the emergence of the language faculty: Much ado about knotting. Ms., Tarragona: Universitat Rovira i Virgili. *LingBuzz*, <http://ling.auf.net/lingBuzz/001397>.
- Manturov, Vassily. 2004. *Knot Theory*. Florida: Chapman & Hall/CRC.
- Mount, John. 1985. *KnotEd: A program for studying knot theory*. [<http://mzlabs.com/JohnMount>] (27 January 2012)
- Miller, Phillip H. 1999. *Strong Generative Capacity*. Stanford, CA: CSLI Publications.
- Pratt-Hartmann, Ian. 2010. Computational complexity in natural language processing. In Alexander Clark, Chris Fox & Shalom Lappin (eds.), *The Handbook of Computational Linguistics and Natural Language Processing*, 43–73. Malden, MA: Blackwell.
- Simon, Herbert. 1962. The architecture of complexity. *Proceedings of the American Philosophical Society* 106, 467–482.
- Stabler, Edward. Forthcoming. Recursion in grammar and performance. [<http://www.linguistics.ucla.edu/people/stabler/Stabler10-Recurs.pdf>] (27 January 2012)

- Turing, Alan M. 1954. Solvable and unsolvable problems. In B. Jack Copeland (ed.), *The Essential Turing*, 576–595. Oxford: Oxford University Press.
- Uriagereka, Juan. 2008. *Syntactic Anchors*. Cambridge: Cambridge University Press.
- Wintner, Shuly. 2010. Formal language theory. In Alexander Clark, Chris Fox & Shalom Lappin (eds.), *The Handbook of Computational Linguistics and Natural Language Processing*, 11–42. Malden, MA: Blackwell Publishing.

David J. Lobina  
Universitat Rovira i Virgili  
Departament de Psicologia  
Centre de Recerca en Avaluació i Mesura de la Conducta  
Ctra. de Valls s/n  
43007 Tarragona  
Spain  
[davidjames.lobina@urv.cat](mailto:davidjames.lobina@urv.cat)



# Knots, Language, and Computation: A Bizarre Love Triangle? Replies to Objections

Sergio Balari, Antonio Benítez-Burraco, Marta Camps,  
Víctor M. Longa & Guillermo Lorenzo

Die Philosophie löst Knoten auf in unserm Denken; daher muß ihr Resultat einfach sein,  
das Philosophieren aber so kompliziert wie die Knoten, welche es auflöst.<sup>1</sup>  
L. Wittgenstein, *Zettel*, § 452

## 1. Map of the Problematique (Some Background)

In a series of papers we have been developing a proposal for a novel methodology to ‘read’ the archaeological record in order to overcome a number of problems posed by the reliance of contemporary palaeoanthropology on such ill-defined notions as ‘modern behavior’ and ‘symbolic culture’ (Balari *et al.* 2008, 2011; see also Benítez-Burraco *et al.* 2008 and Balari *et al.* 2010 for some additional background). Our proposal is based on the idea that a formal analysis of the material remains left by our ancestors may prove useful in determining the kinds and amount of cognitive resources deployed to produce such objects, in other words, that manufactured objects are transparent with respect to the biological structures underlying the processes necessary to produce them. By performing such an analysis, we contend, one is capable of inferring the computational complexity of the said cognitive tasks and to advance hypotheses concerning the

---

This work has been funded by the Ministerio de Ciencia e Innovación from the Spanish Government and FEDER (FFI2010-14955 — SB, ABB, MC, VML, and GL; FFI2010-20634 — SB), and the Generalitat de Catalunya (grant 2009SGR1079 to the Universitat Autònoma de Barcelona — SB).

We wish to thank Professor Jaume Agudé of the Barcelona Algebraic Topology Group (UAB) who, to our question, “Do you think the knots of Knot Theory have anything to do with ‘real’ knots?”, immediately answered, “Of course they do, they are models for them!”, and kindly answered many other questions afterwards. He is not to be blamed, however, of any error or inaccuracy we may have committed. We also thank David Hernández for helping us with the artwork of this article. A very special mention should go to Juan Uriagereka, whose many professional appointments prevented him from participating in this reply. He has nevertheless always been encouraging and also provided a number of useful suggestions, although he should not be held responsible of any remaining error or inconvenience.

<sup>1</sup> “Philosophy unties knots in our thinking; hence its results must be simple, but philosophizing has to be as complicated as the knots it unties” (translation by G.E.M. Anscombe).



architecture of the mind capable of performing them. Our hypotheses were framed against the background of a general model of the architecture of minds we only sketched in the papers referred to above, but which cross-fertilized with a parallel proposal to apply the same methodology in the context of the study of animal cognition in general (Balari & Lorenzo 2008, 2009, to appear).

This more general framework relies on the contention that animal minds/brains are all constructed following a very similar pattern. This claim is mostly grounded in the fact that developmental systems tend to follow rather conservative pathways and easily fall into canalization patterns (Waddington 1957) or follow certain developmental inertias (Minelli 2011 and Striedter 2005 for comparative developmental data on vertebrate brains), but also finds support on a number of neuroanatomical, molecular and other kinds of data we'll try to spell out in the paragraphs to follow.

The main architectural component in our model is a core engine or natural computational system (NCS) subserving some (but not necessarily all) of the main cognitive functions of an animal mind, including low-level ones like motor planning and execution. This NCS is a serial, digital, von Neumann machine implemented on an analog, parallel and continuous substrate,<sup>2</sup> which may be modeled by an abstract machine or automaton in the sense of the mathematical theory of formal languages and automata. We call these abstract models 'computational phenotypes' in order to make explicit the idea that computational activity is a phenotypic trait that one can associate to certain specific neuroanatomical configurations. Computational phenotypes are thus abstract characterizations of the basic models of computation implemented by the said neuroanatomical configurations, and since phenotypic differences are eminently structural in nature, it makes sense to capture the differences between computational phenotypes by appealing to differences in structure between models of computation. Therefore, the natural place to look at in order to provide an abstract structural characterization of a model of computation is automata theory as developed in connection with formal language theory. We will have more to say about formal language theory in section 2, especially with respect to its relation to the theory of computational complexity, but for the time being suffice it to say that it is concerned with the structural complexity of 'languages', where 'language' here is a technical term referring to sets specified as collections of strings made up of symbols taken from a finite alphabet. Thus, for example, the set of integers  $\mathbb{Z} = \{\dots, -1, 0, 1, \dots\}$  may be represented in binary by the language made up of strings over the alphabet  $\Sigma = \{0, 1\}$  as  $\mathbb{Z} = \{\dots, 10000001, 00000000, 00000001, \dots\}$ , for an 8 bit system.<sup>3</sup>

---

<sup>2</sup> The idea that the brain is an analog, parallel processor that nonetheless implements serial, digital processes is supported by evidence coming from different fields, such as neural computation (Sarpeshkar 1998, 2009), neurobiology (Alle & Geiger 2006, Shu *et al.* 2006) and neuropsychological models (Zylberberg *et al.* 2011). This, in fact, adds an extra dimension of variation to the ones to be proposed below, namely the possibility that the neural computations underlying certain behaviors follow the analog, parallel path instead of the digital, serial one. We will have nothing to say about that in this paper, but see Balari & Lorenzo (to appear: chap. 8) for discussion.

<sup>3</sup> Unless otherwise stated, and in addition to Chomsky's original papers cited in the text, our basic references in the following informal presentation of language and automata theory are

Since its original development by Noam Chomsky in the late 1950s and early 1960s (Chomsky 1959; 1963), the theory's main goal has been that of classifying languages (in the technical sense just defined) in a hierarchy of increasing complexity, the so-called Chomsky Hierarchy. Traditionally, the Chomsky Hierarchy is assumed to be organized into four classes (sets of languages) related by proper containment as follows:  $\text{Type3} \subset \text{Type2} \subset \text{Type1} \subset \text{Type0}$ . Type3 (regular) languages are the structurally simplest ones and Type0 (recursively enumerable) languages the more complex ones, with Type2 (context-free) languages and Type1 (context-sensitive) languages sitting in between these two extremes of the complexity spectrum.

Now, given that languages are just (possibly infinite) sets of strings defined over a finite alphabet, they incorporate no direct record of their complexity, but, as Chomsky showed, this can be assessed indirectly by studying the complexity of the finite devices capable of specifying them — grammars and automata. As for grammars, different degrees of complexity are obtained by successively imposing constraints on the format of rules to go from unrestricted grammars for recursively enumerable sets to right- (or left-) linear grammars for regular sets. In the case of automata, the difference in structure follows from the constraints on the working memory space the device has at its disposal to perform the computation, with Turing machines having infinite space (and time) resources to work with and finite-state automata having no working memory space at all. This focus on memory space may seem unjustified at first blush, because, unlike the case of grammars, the traditional characterization of automata is not easily seen as a series in which each automaton is defined as an extension of the immediately preceding one. Thus, whereas the pushdown automaton is just like a finite-state automaton with a memory stack (plus the minimal adjustments to its finite control unit to be able to manipulate the stack), the linear-bounded automaton for context-sensitive languages is a Turing machine whose memory working space is constrained by the length of the input string, that is, it can only use the space in the input tape already occupied by the input string. This is clearly a constraint on memory, but it is hard to see how it relates to the structural properties of the stack of a pushdown automaton. This relation only became obvious after the work of K. Vijay-Shanker and David Weir (Vijay-Shanker & Weir 1994, Weir 1992, 1994) who, building on original work by Nabil Khabbaz (1974), showed that a language hierarchy can be defined with context-free languages being the first in the hierarchy and extending into the space of what traditionally fell under the label of Type 1 languages.<sup>4</sup>

Vijay-Shanker and Weir's results came together with the demonstration that the pushdown automaton, the corresponding machine model for context-free grammars, is just a particular instance of a more general class of automata using pushdown storage and differing only in the structure of the storage mechanism. Thus, on the basis of these results, we could conceptualize the universe of languages as a space organized into three properly contained sub-hierarchies of

---

Hopcroft & Ullmann (1979) and Lewis & Papadimitriou (1981).

<sup>4</sup> As far as we can tell, it remains open the question whether this sub-hierarchy includes all recursive languages in addition to just the context-sensitive ones and excludes the recursively enumerable languages that are not recursive.

increasing structural complexity:

- (i) The Regular Hierarchy
- (ii) The Pushdown Hierarchy
- (iii) Unrestricted Systems

Thus, the Pushdown Hierarchy contains all those languages that, like the context-free languages, can only be recognized by an automaton making use of some kind of pushdown storage. Similarly, the Regular Hierarchy contains the so-called Subregular Hierarchy (Rogers & Hauser 2010, Rogers & Pullum 2011) and includes, at its maximal level of complexity, the regular or finite-state systems. The general machine model for the Regular Hierarchy is the finite-state automaton. These systems are devices capable of performing computations — often very complex ones — without resorting to any external storing device. Finite-state automata are, therefore, systems with no memory whose computational power relies exclusively on the (finite) number of states the machine can be in. Pushdown systems, on the other hand, do possess an external storage device (the so-called pushdown stack), which they can manipulate to help and drive the steps of a computation. Complexity within the Pushdown Hierarchy, where Type 2 and Type 1 systems are properly included, increases as the structure of the pushdown stack is made richer and stack embeddings are allowed within stacks, making it possible to perform more and more complex computations without actually altering the basic processing regime of the whole device. Let us emphasize the fact that the only difference between a finite-state automaton and a pushdown automaton is the presence of the memory stack in the latter, but, for the rest, both are essentially the same kind of device, with the minimal adjustments in the finite control unit of the pushdown automaton to allow for the operations of writing and erasing symbols from the stack (or stacks if it is of a more complex type).

Seen in this way, the complexity hierarchy more clearly illustrates that computational power is just a function of memory or, in other words, of the space resources a computational device has at its disposal. This is, according to our proposal, a first dimension of variation for NCSs. More concretely, we would like to suggest that NCSs are constructed on the basis of a very conservative core engine, always following the same processing regime, which can nevertheless be complemented by a working memory device. The presence/absence and sophistication of this working memory component will determine the computational capabilities of the system, such that a NCS with no memory will be less powerful than one with memory, and, within the class of NCSs with memory, those with complex and sophisticated memory systems will be more powerful than those with a more basic working memory.<sup>5</sup>

---

<sup>5</sup> Leaving aside the case of unrestricted systems (Turing machines), which constitute a special case, our bipartite division between a regular and a pushdown hierarchy can also be motivated on computational complexity theory grounds. Thus, regular systems correspond to those languages in the set  $SPACE(k)$ , where  $k$  is an integer, that is to those languages that can be decided in constant space or, in other words, to those languages for which the space resources used by the decision procedure are independent of the length of the input, which

Before we go on, it is important to point out that our use of the term ‘working memory’ has little to do with any psychological model of memory, as for example the Working Memory of Baddeley (2007) and to which Frederick Coolidge and Thomas Wynn (e.g., Coolidge & Wynn 2004, Wynn & Coolidge 2011) have referred in their work on the Neanderthal mind. Our computational phenotypes are, crucially, not performance models, but abstract characterizations of the models of computation over which a full-fledged performance model may be constructed. According to this, a vertebrate brain can thus be characterized in terms of its computational phenotype (Balari & Lorenzo 2008, 2009, to appear), a characterization in complexity terms focusing on the computational model of the NCS that the said brain implements. Thus, if the analysis of some form of behavior reveals that the complexity of the computations necessary to perform the task is equivalent to a finite-state automaton, we can conjecture that the computational phenotype of the NCS implemented in the brain of this creature is, at least, of the regular type; similarly with the other possible computational phenotypes, with the one corresponding to the human NCS being capable of processing language and hence sitting, at least, within the mildly context-sensitive region of the complexity space.

In some sense, then, our proposal can be seen as an extension of an experimental paradigm originally initiated by W. Tecumseh Fitch and Marc Hauser, based on the aural pattern-recognition abilities of cotton-top tamarins and reported in Fitch & Hauser (2004); see also O’Donnell *et al.* (2005) and Rogers & Hauser (2010). The same paradigm was later applied to starlings, with seemingly equal success by Gentner *et al.* (2006), although it has been subjected to several criticisms from different quarters (e.g., Perruchet & Rey 2005, Heijningen *et al.* 2009, Petersson *et al.* 2010, Rogers & Pullum 2011). The main difference between what we are proposing here and the assumptions of aural pattern-recognition experiments is that instead of focusing on learning capabilities our suggested methodology proceeds in the reverse direction, from the behavioral patterns the subject is naturally capable to perform to their structural complexity and, from there, to the minimal model of computation required for the task, and it is thus immune to the shortcomings observed by, for example, Rogers & Pullum (2011) that affect aural pattern-learning experiments.

Thus, what we have characterized here as a NCS roughly corresponds to what Hauser *et al.* (2002) called the Faculty of Language in the narrow sense (FLN), but our characterization is broader in the sense that we do not conceive of our NCS as either language-specific or human-specific. Indeed, even though we follow Hauser *et al.*’s (2002) methodological proposal of distinguishing between narrow and broad aspects of some cognitive ability, we deny to their FLN its human and language specificity, whence our terminological switch here to NCS.<sup>6</sup>

---

is tantamount to saying that no memory is required in the process. For all languages in the pushdown hierarchy, on the other hand, the space resources spent during decision will be some function of the length of the input, and consequently some storage mechanism is required. We come back to this in section 2, but see Papadimitriou (1994) for details.

<sup>6</sup> Something that — we are ready to acknowledge this — we should’ve done before in order to avoid misunderstandings stemming from our infelicitous use of FL in contexts in which the term was clearly inappropriate.

Now, from all this it follows that NCSs are functionally unspecific devices, i.e. not specially tailored to perform one or another cognitive task. NCSs just are capable of executing a recursive procedure capable of constructing more or less complex representations as a function of the input and the memory resources available.<sup>7</sup> NCSs therefore, in order to be operative, need to be connected to some external modules supplying their input and capable of receiving their output. Seen from this perspective, external modules impose a number of constraints on the workings of a NCS, mostly concerning certain properties having to do with the nature of the input and certain properties concerning the nature of the output, but, crucially, these constraints will have little, if anything, to say about certain structural properties of the objects produced by the NCS, since these will critically depend on the memory resources available to the recursive procedure implemented by the NCS. There is thus a tension between the interface conditions imposed by the external systems and the computational capabilities inherent to the NCS which defines a two-dimensional space of variation, with one of the axes corresponding to the working memory space the NCS has access to and the other axis corresponding to the number and kind of the external systems the NCS interfaces to. Thus, following Hauser *et al.* (2002), the minimal architectural requirements for human language are a NCS with a computational power at least equivalent to that of a mildly context-sensitive system interfaced to a Sensory-Motor module and a Conceptual-Intentional module.

Putting now this whole view in a broader perspective, note that this model opens up new avenues of research within the field of cognitive archaeology in particular and cognitive science in general, since, given the two dimensions of variation we envisage here, a number of different possible configurations for 'other minds' can be imagined. For example, it is possible that a linguistic phenotype has existed with the same external systems as the human one but interfaced to a less powerful NCS; or one lacking some of the interfaces necessary for the full externalization of thought; or one simply not yet fully satisfying the interface constraints imposed by the external systems; similarly for other cognitive abilities different from language, and as already suggested above, for other cognitive abilities in other animal species. The question, of course, is eventually an empirical one, and the methodology we are proposing here can be, in our opinion, a useful tool for clarifying all these questions.

The general model we've just outlined in the foregoing discussion is not merely a product of our speculations, but, as we pointed out at the beginning of this section, there exist numerous pieces of evidence coming from several other

---

<sup>7</sup> The issue of 'recursion' has become a debated question since, at least, the publication of Hauser *et al.* (2002). Here, following Tomalin (2007, 2011), we will adhere to the terminological distinction between 'recursion' and 'self-similar embedding'. The first term refers to the property, common to a number of computational devices, of being able to take as input a number of objects of some specific type in order to produce a new object or set of objects of the same type which in turn may later feed a subsequent step in the computation to produce new objects of the same type and so on. The second one refers to a structural property observed in the objects produced by certain computational devices with the appropriate memory resources (minimally, a push-down stack), like, for example, expressions in a natural language. Thus, to get objects with self-similar embedding some recursive procedure must be applied, but not all applications of a recursive procedure necessarily yield objects with the property of self-similar embedding.

areas of research that seem to point in the same direction. What follows is a brief delineation of this evidence.

To begin with, there exists abundant clinical evidence suggesting the comorbidity among diverse disorders entailing deficits of diverse sort that can be yet construed as equivalent in computational terms. For instance, people affected by Williams-Beuren syndrome exhibit linguistic (Karmiloff-Smith 2006) and visuo-spatial deficits (Hudson & Farran 2010), which are interpretable in terms of processing problems with context-free and context-sensitive operations. Similarly, the prevalence of drawing deficits among dyslexics is a well-known fact, which invites to explain their state in terms of a visuo-constructive deficit (Eden *et al.* 2003, Lipowska *et al.* 2011), or even better, of a more general deficit affecting the rule abstraction mechanism inherent to sequential learning, which would impair both linguistic and visuo-motor abilities (Vicari *et al.* 2005, Pavlidou *et al.* 2010). Finally, it is also commonly observed that language and motor deficits co-occur developmentally (Webster *et al.* 2005, Cheng *et al.* 2009, Iverson & Braddock 2011; see Rechetnikov & Maitra 2009 for a meta-analysis), implying that voluntary motor actions entail diverse motor primitives or ‘movemes’ (Del Vecchio *et al.* 2003) arranged in different ways according to specific combinatorial or syntactic rules (see Flash & Hochner 2005, and references cited therein). All this well-attested comorbidity is easily explained if one and the same computational device is affected.

Current neurobiological research provides us with the most compelling evidence for the plausibility of our model. For example, dissimilar linguistic modalities, such as sign and spoken languages, otherwise equally complex in structural terms (Brentari *et al.* 2010), are processed by similar brain mechanisms, as attested by numerous neuro-imaging and lesion studies (MacSweeney *et al.* 2008, among many others). This evidence gives support to the idea that the NCS is unspecific in functional terms, but capable of coupling to different modules for exteriorizing its outputs. Besides, the brain seems to remain on basic neural ‘binding mechanisms’ (like cortical synfire chains) to generate any kind of composite objects at the representational level (Flash & Hochner 2005: 663), and there is ample neuro-imaging evidence supporting the hypothesis of different kinds of computations being performed by a ‘central’ device (see Dipietro *et al.* 2009 with regards to drawing). Eventually, fMRI studies show that similar patterns of activation arise in response to diverse tasks if they are computationally equivalent, ultimately suggesting that the same brain areas (and plausibly, the same computational device) are involved. For instance, drawing bilaterally activates a wide network of subcortical and cortical structures (Makuuchi *et al.* 2003), many of which are also involved in language processing (see Makuuchi 2010 for a review).

Although the precise topography of the neural substrate of such computational device is somehow controversial, it plausibly relies upon the coordinated activities of diverse brain areas, both cortical and subcortical. For instance, according to Lieberman (2000, 2002, 2006) language is tantamount to a computational device capable of processing symbolic elements, with this device conceivably being the outcome of the interaction between a sequencer (the activity performed by the basal ganglia) and a working memory (the activity

executed by diverse cortical structures). In a similar fashion, Ullman (2001, 2004) has hypothesized that a procedural memory exists (ultimately emerging from the coordinated activities of a complex network of cortical, subcortical, and cerebellar neuronal populations) that allows for the existence and functioning of “the mental grammar, which subserves the rule-governed combination of lexical items into complex representations” (Ullman 2004: 231). Crucially, both Lieberman’s computational device and Ullman’s procedural memory are ultimately conceived as to subservise the learning and execution of diverse tasks, both linguistic and non-linguistic, so when this neural architecture is damaged an admixture of both linguistic and non-linguistic symptoms are observed in affected people.

This is the case, for instance, of Huntington disease, a neurodegenerative condition in which a defective variant of the HD protein accumulates in the cell nucleus and cytoplasm, specifically killing the GABAergic neurons of the caudate (Gusella & MacDonald 2006), and thus plausibly disturbing the neural substrate of the sequencer in our model. In affected people pervasive problems with the application of rules are observed during language processing; however, the disease also encompasses a defective processing ability of motor routines, as well as other diverse cognitive deficits and psychiatric disturbances (Gusella & MacDonald 2006). Other neurological pathologies affecting the basal ganglia exhibit quite similar phenotypic profiles. For example, Parkinson disease is also caused by a selective damage of some components of this subcortical region, to be precise, the dopaminergic neurons that project to the *substantia nigra* (Surmeier *et al.* 2010). Once again, linguistic and motor deficits regularly co-occur in affected people (Grossman *et al.* 1991, Duffy 2005). In the whole, we recurrently observe that language disabilities correlate to a variety of neuropsychological and motor changes in all these conditions (see Murray 2000, for a review of Huntington and Parkinson diseases).

The abnormal development of this neural circuitry through mutations of any of the genes involved in its organization also renders symptoms that are not domain-specific. A classic (but still illustrative) instance is the first mutation to be identified on *FOXP2*. In people bearing the R553H substitution, the primary pathology is located in the caudate, but other brain regions, otherwise relevant for language processing, are also structurally and/or functionally impaired (Vargha-Khadem *et al.* 1998, Watkins *et al.* 2002a, Belton *et al.* 2003, Liégeois *et al.* 2003). In fact, there is ample evidence supporting some key role of *FOXP2* in modulating the development and functioning of (specific) cortico-thalamic-striatal circuits associated to motor planning, sequential tasks, and procedural learning (for a review, see Marcus & Fisher 2003, Vargha-Khadem *et al.* 2005, Fisher & Scharff 2009), a brain network which could plausibly match the neural substrate of our NCS. Although there is a hot dispute around the precise phenotypic profile (and the underlying deficit) of the disorder linked to the mutation of the gene, motor and linguistic deficits are simultaneously observed in affected people (Gopnik 1990, Vargha-Khadem *et al.* 1995, Watkins *et al.* 2002b, Vargha-Khadem *et al.* 2005, Shriberg *et al.* 2006), thus precluding this condition from being merely characterized as a speech or even a (specific) language disorder. Animal models reinforce the functional unspecificity of the neural circuitry *FOXP2* contributes to (Shu *et al.* 2005, Fujita *et al.* 2007).



Finally, acquired damages of important constituents of the neural substrate of our NCS also give rise to deficits of diverse condition, eventually reinforcing the functional non-specificity of the device. For example, a focal damage of the left basal ganglia (in particular, of certain frontal-subcortical circuits) symptomatically manifests as a decreased ability in both verbal and visual modalities (Troyer *et al.* 2004), and both limb movements and language are impaired when cortico-basal ganglia-thalamo-cortical circuits are damaged, as observed in drawing, overwriting and repeating words and phrases in absence of external commands (Fung *et al.* 1997).

This is just a sample we've recently compiled, which could easily be extended with further data, but one that clearly suggests that evidence from neurobiology is amenable to an interpretation entirely compatible with the model sketched here.

That said, we let's turn now to the objections.

## 2. The Correct Use of Soap (and a Conclusion)

Now that we have provided a detailed account of our ideas, we are in a better position to address David J. Lobina's criticisms. We will start, however, with some general comments on a point Lobina does not directly touch on in his note, but which remains implicit in most of what he says, so we deem it necessary to get into that before turning to other issues.<sup>8</sup>

A key feature of our proposal is that the processing capabilities connected to FL in humans are independent from any domain of conceptual primitives, even those dedicated to belief fixation, planning, and the like ('thought', roughly speaking) that, according to recent minimalist theorizing, conflate with FL into a unitary domain (Hinzen 2006, Chomsky 2007). Notwithstanding the fact that Lobina refrains from discussing general features of mental architecture in his paper, a clarification of our particular view of the computational mind is in order, as he has elsewhere referred to it as "bizarre", "incoherent", and "strange" (Lobina 2012) and continues to cast doubt on its soundness in the *Biolinguistics* piece (this issue, p. 76), attributing to us assumptions that we do not really share.

As a matter of fact, we do share certain background assumptions with Lobina, to wit: (1) That thoughts are *bona fide* (i.e. contentful) representations; and (2) that contentful representations are language-like entities — i.e. something along the lines of Fodor's 1975 LOT hypothesis (Lobina 2012: 2–3).<sup>9</sup> We think that these are reasonable assumptions, but not because their truth is somehow warranted: Thoughts could happen to be some kind of brute-causal associationist networking, instead of contentful representations, and contentful representations could happen to be map-like, instead of language-like, entities. Yet, as observed for example by Devitt (2006), (1) and (2) are the most successful hypotheses thus far in predicting other people's behavior as well as in explaining the productivity and systematicity of thought, among other things; in other words, it is not their

<sup>8</sup> All references to Lobina's work including only a page number are to his paper "All tied in knots", published in this issue of *Biolinguistics*.

<sup>9</sup> This other paper by Lobina is not paginated, so page numbers in our references to it should be interpreted as 'first page', 'second page', and so on.

purported truth what makes them respectable, but rather their explanatory force. We share this set of convictions with Devitt, as we think Lobina does.

So we accept (with Lobina) the idea of an autonomous thought domain, whose primitives are easily accessible for computations that map them into complex thoughts. However, the thesis that the processing competence that we use in composing meaningful expressions (say, sentences) is inextricably linked to the existence of rich contentful, language-like thoughts (which Lobina mistakenly attributes to us) is not in our opinion a favored hypothesis on plausibility grounds similar to that of (1) and (2). Thus, contrary to the adoption of the representational theory of mind and the LOT hypothesis as default premises given the state of the art of cognitive science and philosophy of mind, a similar move is far from warranted with respect to the question of intrinsically connecting the processing capabilities of mind with the kind of concepts and intentions that it is able to deal with. The clearest statement in this direction that we are aware of presents this processing competence as an adaptation to the evolved function of composing (and subsidiarily expressing) complex thoughts (Devitt 2006, Chomsky 2010). We think, however, that adaptationism provides no sufficient grounds for favoring such a hypothesis, for reasons that are explained at length in Fodor & Piattelli-Palmarini (2010). Here we just want to remember that George C. Williams, one of the most brilliant evolutionary biologists of the 20<sup>th</sup> century and an adaptationist himself, defended that adaptations, far from being seen as default explanations, should be treated as explanatory last resorts. The reason is simple: The long, cumulative and highly complex chains of events leading to true adaptations are not to be expected to occur very frequently (Williams 1966). So the idea that a processing competence exists as an adaptation for the elaboration and expression of thoughts is not one to be contemplated in the absence of very (very) strong evidence and, as a first move, we should reject it.

The impact of these observations on establishing and exploring a reasonable view of the architecture of mind is in our opinion clear: The thesis that there exists a processing competence inextricably and exclusively connected to the rich conceptual competence in charge of belief fixation and the like loses all the beforehand motivation that it has under the umbrella of adaptationism; and so, we become free to explore the alternative idea that the said competence has an independent evolutionary history, not linked to any conceptual, sensory or motor domain in particular, as well as the complementary idea that it has gained access to different cognitive domains throughout hominid evolution (or evolution without more qualifications, as it could happen to be a very ancient trait; see Balari & Lorenzo 2008, 2009, to appear). The idea boils down to the supposition that humans make complex beliefs for the same reasons that they make complex arguments, complex paintings, complex poems or complex knots (which is not to say that knots, poems, paintings, and especially arguments are always complex). In other words, we support the idea of decoupling linguistic competence into autonomous components, in the spirit of Hauser *et al.* (2002) save the important detail that we envision its core processing component (i.e. the NCS) as not language and not even human specific. We honestly wonder what is so weird about this idea. Its truth is not warranted, of course (as almost everyone else's

ideas in the field), but it opens paths worth being explored (and more clearly amenable to empirical testing than most theses in the field). Are we not Fodorian enough? Not neo-Chomskyan enough (perhaps to Lobina's surprise)? Granted, but to this we can only reply one thing: There's life beyond authorities.

Therefore, it is against this general background that must be construed our claim that some important aspects of knot-tying abilities might be parasitic on language in humans. According to our view, whatever cognitive modules participate in knot-tying abilities crucially share the same computational basis with those participating in linguistic abilities. We will immediately turn to knots, but, before, we'll need to go back to automata, performance models and computational complexity.

Lobina's criticisms are articulated along two main themes: Our purported misuse of complexity results deriving from formal language theory and the theory of computational complexity, on the one hand, and what in his opinion is an illegitimate appeal to topology in our claims concerning knotting abilities in humans, on the other. Both points are eventually connected, but we shall respond to them in turn, and only towards the end will we be able to tie all the threads together.

As for the first point, Lobina pretends that we are mixing questions of weak generative capacity with questions of strong generative capacity and leaping from there to illicitly inferring that natural language has a specific inherent computational complexity. It appears then that some steps in the argument have escaped Lobina's attention, so we'll try to spell them out in full.

Recall that the Chomsky Hierarchy classifies languages according to their structural complexity and that such complexity can only be assessed through the devices that are capable of specifying one or another language. Thus, if the structural complexity of a set can only be assessed with respect to one or another model of computation, it should not come as a surprise that Chomsky has always insisted on the fact that what is important in the study of a language (*any* language, natural languages included) is its grammar, not just the strings that make it up. This observation is at the core of the whole generative linguistics enterprise, since, as also pointed out by Chomsky, there are many possible different grammars one can think of capable of generating exactly the same stringset; we shall say in this case that these grammars are all 'weakly equivalent' or that they have the same 'weak generative capacity'.

The challenge, when our focus of interest is natural language, is, therefore, which of all the imaginable weakly equivalent grammars is the one that really captures the actual structure of natural language expressions or, using Chomsky's own words, which grammar is the descriptively adequate one. Note that descriptive adequacy is defined not just with respect to weak generative capacity but, rather, with respect to a stronger condition incorporating the notion of structural description. Thus, two weakly equivalent grammars are not necessarily also 'strongly equivalent', i.e. they do not necessarily assign the same structural descriptions to the strings of a set or have the same 'strong generative capacity'. Note that the notion of strong generation somehow transcends the notion of model of computation, since grammars and automata as defined in formal language theory, are only weak generators, not strong ones, they do not

assign structural descriptions to strings in a set.

Importantly, though, this does not make all the complexity results presented in the preceding discussion irrelevant, because another crucial outcome of Chomsky's original work is that, whatever the descriptively adequate grammar for natural language eventually turns out to be, its power will be beyond that of context-free grammars, and, as shown in later work also reported above, it most probably lies within the power of a mildly context-sensitive one. These are "the limits of finite-state description" (and of context-free description) that according to Chomsky (1956, 1957) force linguistic theories to turn to more powerful devices than finite-state and context-free grammars. Thus, the only reason for saying that the grammar of a natural language is some mildly context-sensitive grammar is precisely that only a grammatical formalism of this power will be able to generate the appropriate structural descriptions. Note, however, that these complexity results refer to the inherent structural complexity of natural language and are therefore independent from the kind of grammatical formalism we may want to favor as our theory of linguistic competence. They set a lower bound of complexity in the sense that an adequate grammatical formalism should possess at least the same expressive power of a mildly context-sensitive grammar. Now, since for each grammar there is a corresponding automaton, it doesn't make much difference on which perspective we want to put the emphasis when concerned with such inherent structural complexity of language.

Moreover, as the preceding discussion suggests, we must assume that a type-token relation exists between a grammar of a specific type (say, a context-free grammar) and a grammar generating some specific language (say, some context-free language); similarly with automata. Our computational phenotypes are types precisely in this sense, and, consequently, to repeat, they are not — cannot be — performance models, just basic specifications from which performance models can be built. Thus, if we ever wanted to build a parser P (a strong generator) for some language given some grammar G, we should base our construction on the appropriate model of computation A (a weak generator), because parsing presupposes recognition. That much seems to have escaped Lobina's attention, as he constantly insists on stating that automata are just recognizers and not generators, but as Chomsky (1963: 332) already made clear a long time ago:

"It is immaterial whether we picture an automaton as a source generating a sentence symbol by symbol as it proceeds from state to state or as a reader switching from state to state as it receives each successive symbol of the sentence it accepts."

And, if any doubt was left about the fact that parsing presupposes recognition, take the following quote from Earley's (1970: 95) original paper describing his popular parsing algorithm for context-free grammars:

"A *recognizer* is an algorithm which takes as input a string and either *accepts* or *rejects* it depending on whether or not the string is a sentence of the grammar. A *parser* is a recognizer which also outputs the set of legal derivation trees for the string." (Emphasis in the original.)

Thus, since our proposal is clearly noncommittal to any specific model of grammar, a large part of Lobina's subsequent observations concerning grammar formalisms and parsers constitute a blatant *non sequitur* that only adds confusion and deviates the discussion from the real point. And the point is, in this case, that anyone interested in building a performance model should pay attention to these structural facts concerning the complexity of human language in order to be successful. But not just to these, because there are also questions of computational complexity that need to be taken into account. Enter the theory of computational complexity, then.

Before getting into the details, it is crucial to make clear that both the Chomsky Hierarchy and the theory of computational complexity are concerned with languages and with their classification into classes.<sup>10</sup> Of course, the criteria for their classification are different in each case, but it is important to see that some language that falls in some class in the Chomsky Hierarchy will also show up in some computational complexity class and therefore connections can be established between the inherent structural complexity of this language and its inherent computational complexity. Thus, as we already pointed out in footnote 5 above, the languages that fall within the regular class in the Chomsky Hierarchy are exactly the ones conforming the SPACE(k) class of computational complexity theory, therefore we know that any two regular languages (i.e. of identical structural complexity) have also the same computational complexity. This point is critical, because anyone failing to appreciate this might fall in the trap of believing that we are juggling with complexity classes and jumping from one perspective to the other and back without much justification. We're afraid we were jumping too fast, so let's proceed at a slower pace.

Computational complexity theory is concerned with sets but it looks at them as if they were problems. As with any problem, we want to know if there's a solution forthcoming in the near future and, in this case, how hard it is to solve it.<sup>11</sup> The point here is that any problem we may think of can be represented as a language and, accordingly, that everything reduces to analyzing the complexity of language recognition problems. Since structural complexity is here not an issue, there's no need to consider different models of computation, indeed, the strategy is to fix a specific model of computation and to see how it behaves when dealing with different problems. The model of computation of choice for computational complexity theory is the k-string Turing machine, which can however be set to operate at different modes of computation — deterministic and nondeterministic — in order to establish certain complexity measures.

Finally, complexity is defined as the amount of time and/or space resources spent by the machine in order to solve the problem, where time is defined as the number of steps needed to solve the problem and space as the

---

<sup>10</sup> Our basic references for this presentation of computational complexity theory are Lewis & Papadimitriou (1981) and Papadimitriou (1994).

<sup>11</sup> Therefore, the universe of sets the theory of computational complexity deals with very much transcends that of the Chomsky Hierarchy, since it sometimes discovers that some sets represent utterly intractable problems, that are not even recursively enumerable. Remember that the Chomsky Hierarchy includes only all the recursively enumerable sets, but not the non-recursively enumerable ones.

number of cells in the tape visited by the machine during the computation. There's a twist here, however, that needs to be made explicit to make complexity results more understandable. Turing machines are very powerful devices and, in principle, they have unlimited amounts of time and space to perform a computation and, since when concerned with problems we also want to know if they can be solved efficiently, we need to put some constraints to this unlimited capacity of Turing machines. For this reason, computational complexity theory is actually concerned with defining the time and/or space bounds within which a problem can be solved efficiently. The usual practice is to determine the upper bound, i.e. the worst case, beyond which efficiency severely degrades, but it is also possible to determine a lower bound of complexity for a problem, such that if we are able to determine that the lower bound for a problem is in complexity class  $C$ , we know that the problem is at least as hard as any of the hardest problems in  $C$  (it could be harder), and we say that the problem is  $C$ -hard.

Now, back to complexity measures in terms of time and space, these are defined as functions on the length of the input string telling us the rate at which time or space grow as the length of the input grows, expressed  $f(n) = O(g(n))$ , where  $n$  is the length of the input. There are different possible functions of this kind, but the ones that most concern us here are  $O(n^c)$  and  $O(c^n)$ , where  $c$  is a constant in both cases, and referred to as polynomial and exponential, respectively. Thus, when we say that an algorithm runs in time  $O(n^3)$ , as it is the case with Earley's (1970) parser, for example, we are actually stating that, in the worst case, it will spend an amount of time equal to the cube of the length of the input, and we will classify it in the class  $\text{TIME}(n^3)$ . Note that, in principle, there are infinitely many  $\text{TIME}$  classes like the preceding one since the exponent of the function can be any integer,<sup>12</sup> but all sharing the property of defining polynomial time bounds. The union of all these classes is the complexity class  $\mathbf{P}$ . Given this definition, it is clear that  $\mathbf{P}$  is in fact a hierarchy of polynomial time classes, with some classes including harder problems than others. The hardest problems in  $\mathbf{P}$  are the  $\mathbf{P}$ -complete problems, where a  $C$ -complete problem,  $C$  a complexity class, is a problem that is at least as hard as any of the hardest problems in  $C$  (i.e. it is  $C$ -hard) and it is known to be in  $C$ .<sup>13</sup> Moreover,  $\mathbf{P}$  is a deterministic class, meaning that any problem within this class can be solved efficiently in polynomial time by a  $k$ -string Turing machine working in deterministic mode.

Nondeterministic time classes are a bit different. This is mostly due to the fact that non-determinism is still a poorly understood notion and that the definition of recognition is weaker for nondeterministic Turing machines than it is for deterministic ones (Papadimitriou 1994: chap. 2, for details). Given the fact that a nondeterministic Turing machine, at any point of the computation, has at least two choices to follow, time measures do not refer to all the possible steps in a single computation (these would be too many) and are calculated differently

---

<sup>12</sup> Another assumption within computational complexity theory is that the exponents in polynomial functions are somehow 'well-behaved' in the sense that they never become too large to make the problem effectively intractable, even if polynomial.

<sup>13</sup> Complete problems are thus 'model' problems since both their lower and their upper complexity bounds are defined by the class they belong in, e.g., a  $\mathbf{P}$ -complete problem is at least as hard as any problem in  $\mathbf{P}$ , but not harder.

assuming that at least one path yields to acceptance. The most important non-deterministic time class is **NP** (for Nondeterministic Polynomial) and, like **P**, is defined as the union of all nondeterministic classes with polynomial characteristic functions. The discovery that some problem is in **NP** means that the Turing machine will reach a solution following some path and that the correctness of the solution can be verified through a succinct certificate (or polynomial witness) in polynomial time. The succinct certificate is an external device that can be consulted every time a 'yes' state has been reached and that provides an efficient procedure to check the result.<sup>14</sup> As we will see presently, the existence of succinct certificates for all problems in **NP** is a datum that in some cases has been interpreted as having implications for cognitive science.

Turning briefly to space complexity classes, these are constructed in exactly the same way as time complexity classes, with the proviso that space is taken to be a more costly resource than time because it can be reused. In the case of space, then, polynomial functions identify very hard problems, close to intractability. For this reason, when dealing with space, logarithmic or linear bounds are preferred over polynomial bounds, although the class that will be of interest for us here is, precisely, **PSPACE** (for Polynomial Space), which is a deterministic class.

Finally, the three classes considered here are related by inclusion, composing the following hierarchy of increasing complexity:  $\mathbf{P} \subseteq \mathbf{NP} \subseteq \mathbf{PSPACE}$ . Note that the inclusions are not known to be proper, meaning that the classes might turn out to be equal. Indeed, the question whether  $\mathbf{P} = \mathbf{NP}$  is one of the most important unsolved problems in complexity theory.

Now, back to natural language, we've seen that, structurally, it is more complex than context-free but less than context-sensitive, with a structural complexity equivalent to that of a mildly-context sensitive language. Recall that these complexity results refer to sets and that these very same sets will appear as members of some computational complexity class represented as recognition problems. The problem **CONTEXT-FREE RECOGNITION**<sup>15</sup> is in **P**; the problem **CONTEXT-SENSITIVE RECOGNITION** is in **PSPACE**;<sup>16</sup> then, the problem **MILD-CONTEXT-SENSITIVE RECOGNITION** should fall somewhere in between, or within any of the two bounding classes. Note that this inference is entirely independent from any consideration concerning parsing, choice of grammatical formalism, or any other architectural or formal consideration about performance models. It is, if anything may be characterized in this way, a fact following from the inherent structural properties of the languages considered and from their analysis as recognition problems. Now, thanks to the work of Eric Sven Ristad, we can add some very interesting results to the previous inference that square perfectly with it.

Very briefly, but see Ristad's (1993) monograph for the details, Ristad

<sup>14</sup> Therefore, the definition of **NP** that Lobina gives his note is, to say the least, non-standard, when he writes that "the algorithm will define multiple ways of processing the input without specifying which one it will take, in polynomial time" (p. 75).

<sup>15</sup> We follow the established convention in computational complexity theory of setting problem names in small capitals.

<sup>16</sup> It is in fact **PSPACE**-complete.

analyzed the inherent computational complexity of some linguistic problems and came to the conclusion that natural language computations are **NP**-complete. The relevance of Ristad's results, regardless now of their accuracy, is that he derived them independently of any consideration concerning specific linguistic theories, performance models, and so on, which, in his opinion, legitimizes his claim that "[t]he upper and lower bounds of our proposed complexity thesis are tight enough to tell us exactly where the adequate linguistic theories are, not only where they are not" (Ristad 1993: 14). Thus, Ristad takes his results as something with strong implications at the time of building competence/performance models, in the sense that these models will have to be accommodated to the inherent **NP**-completeness of natural language.

Indeed, according to Ristad, the fact that language is in **NP** runs against the modularity thesis, as he interprets the existence of the certificate as the demonstration that the computational system subserving language has access to external information available to verify the correctness of the computations. This is not a proof, of course, but it is a good example of how mathematical results may have some bearing on hypotheses in cognitive science and may help to articulate them, something, by the way, that Lobina sees with a big dose of skepticism when he writes (p. 74) that "the computational complexity of natural language processing will have to consider properties of human psychology such as memory limitations, the strategies that are employed in parsing, the use of the immediate context and many other factors. All in all, it is simply not known what computational complexity our mental machinery exhibits in the processing of language". We, on the other hand, with Ristad, rather believe that it is the task of psycholinguists to incorporate these results when building their performance models, that whatever memory limitations they postulate, whatever parsing strategies they propose, etc., should take into account the inherent structural/computational complexity of natural language. It is perhaps a matter of epistemological priority — what should come first? — and, certainly, a debatable one, but nothing in Lobina's piece actually suggests that he has even the hint of an argument against this idea nor against the idea that this very same strategy can be fruitfully applied to other domains of cognition.

Let's turn to knots, then. To start with, remember that our hypothesis that human knotting abilities might be 'parasitic' on linguistic abilities must be interpreted in the context of an architectural model for (some areas of) the mind according to which a single NCS may underlay more than one cognitive ability. The term 'parasitic' is therefore to be interpreted in the sense of 'sharing computational resources', with such resources being a NCS with specific computational properties. Whence our proposal that, if the complexity of the cognitive tasks associated to knotting abilities were equivalent (or higher, we cannot discard this possibility *a priori*) to that of linguistic abilities, this could constitute an indirect datum at the time of reading the archaeological record, which, so far, shows a strong correlation between the presence of language and knotting. In our attempt to ground on a more formal basis Camps & Uriagereka's (2006) original insights in this connection, we turned our attention to topology and the mathematical



theory of Knots.<sup>17</sup> Lobina finds this outrageous mostly because “the knots that [Knot Theory] studies have nothing to do with real knots” (p. 74), to which it should be added our presumed misinterpretation of a number of complexity results in Knot Theory. We’ll discuss these in turn.

Leaving aside Lobina’s bold statement, we would like to note first that Knot Theory is not as disconnected from ‘reality’ (whatever that means) as Lobina wants us to believe it to be. To be sure, Knot Theory was originally motivated to solve a number of problems in organic chemistry and it has thereafter found a number of other applications in several areas of biochemistry and physics; see Adams (2004) for some historical background and examples of these applications. Obviously, that Knots find their application in organic chemistry, for example, is not a demonstration that a relation also exists with the knots one uses when sailing, fishing, mountain climbing, or building a hut. We could cut that story short by just referring to the acknowledgements footnote in the opening of this paper, but we’d rather dwell on this a bit more in order to try to unearth the reasons behind Lobina’s skepticism.

One such reason could be the fact that a Knot is defined as an embedding of a circle ( $S^1$ ) into a sphere ( $S^3$ ) — denoted  $S^1 \rightarrow S^3$  — or, alternatively, as an embedding of  $S^1$  in Euclidean space  $\mathbb{R}^3$ . That much has the net effect that a Knot must be visualized as a closed structure and not as an open one, as it would be the case, for example, with a sailing line tied to get a bowline. Note, however, that this definition is adopted essentially for practical purposes, since it ensures that Knots are finite objects, but, apart from that, nothing prevents us to define a Knot as the embedding of a tangled line whose two ends extend infinitely into  $\mathbb{R}^3$  (Jaume Aguadé, p.c.). Well, yes, there’s yet another reason: The embedding could not then be in  $S^3$  (the sphere being a surface delimiting an area of space  $\mathbb{R}^3$ ), given the infinite length of the line, and the homeomorphisms defined in order to determine equivalence relations between Knots could not then be defined as  $S^3 \rightarrow S^3$  (i.e. relations between embeddings in a sphere), and should be defined differently. That much, in our opinion, should nevertheless not obscure the fact that Knots can legitimately be taken as models for knots. To strengthen this point, consider the following (informal) definition of a Knot in terms of a knot by Adams (2004: 1–2):

Take a piece of string. Tie a knot in it. Now glue the two ends of the string together to form a knotted loop. The result is a string that has no loose ends and that is truly knotted. Unless we use scissors, there is no way that we can untangle the string.

A *knot* is such a knotted loop of string, except that we think of the string as having no thickness, its cross-section being a single point. The knot is then a closed curve in space that does not intersect itself anywhere.

This is a fairly intuitive way of describing a Knot and we invite the reader to follow Adams’s recommendation and to tie an overhand knot and close it afterwards (an electrical extension cord is good for the experiment because it can

---

<sup>17</sup> In the following discussion we will capitalize the word ‘knot’ when referring to mathematical entities in order to distinguish the Knots of Knot Theory from the knots of sailors, for example.

be plugged to itself in order to close the knot... or is it a Knot?); or try with a bowline (in both its British and Dutch versions) to see that it is equivalent to a Knot with six crossings. Some fiddling will perhaps be needed with the cord, but, with some practice, one will eventually be able to get something that clearly resembles the standard representation of a Knot (Figure 1).

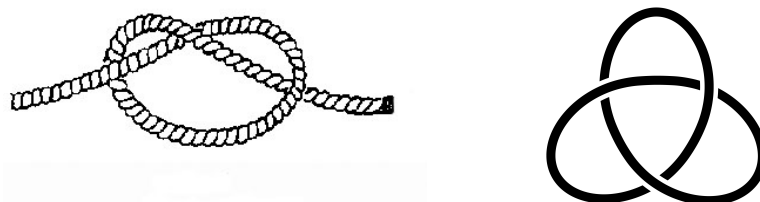

Figure 1: The overhand knot (left) and the trefoil Knot (right). Just close the two loose ends of the knot to get the Knot. (The trefoil image has been generated with the KnotPlot© software developed by Rob Scharein.)

For the sake of completeness, Knots can also be represented in a format that comes closer to knots in the form of braids. A braid is a collection of vertical lines fixed at their two ends to two rigid parallel horizontal bars, such that when they are not tangled each line cuts a horizontal plane parallel to the two bars only once. In fact, a knot more closely resembles a braid consisting of a single knotted line, but it happens that braids are Knot generators, such that when we detach them from the bars and we close them we get a Knot.<sup>18</sup> Braids and Knots are therefore equivalent such that, for example, the trefoil (or threefoil) Knot and its equivalent braid (the overhand knot) can be described by the same braid word  $\sigma_1^3$  (Adams 2004).

Anyway, a criticism based on the purportedly illegitimate application of the mathematical theory of Knots to some aspect of ‘reality’, apart perhaps from upsetting a fair number of mathematical realists, strikes us as the same as contending that those areas of physics, chemistry or musical theory that make a fruitful use of group theory are incongruous just because groups are such abstract algebraic structures and so much divorced from reality — what on earth has a group to do with the structure of crystals? That’s outrageous!

So much for the question of legitimacy. Of course, from the fact that Knots are perfectly good models for knots it does not follow that they are good models for *cognitive* representations of knots. This point certainly deserves some attention.

One of the inconveniences one faces when trying to investigate the cognitive abilities involved in the act of tying a knot and in the (creative) act of inventing one<sup>19</sup> is the lack of relevant studies on the topic. So far, the only studies

<sup>18</sup> Not always, i.e. not any closed braid actually generates a Knot, but the reverse is true: Any Knot is equivalent to a closed braid.

<sup>19</sup> Lobina (2012: 10) accepts the possibility that “many knots in history came about accidentally”. Well, maybe, but not very many of them. Everyone minimally acquainted with knot tying techniques will see this: Perhaps the overhand knot did, but it is highly improbable that the same happened with, for example, the bowline.

we have been able to track down concern experiments with humans or apes (see Michel & Harkins 1985 and Tracy *et al.* 2003 for humans and Herzfeld & Lestel 2005 for apes), focusing on the learning of the relevant motor sequences needed to produce a number of (relatively simple) knots. An interesting aspect of these studies is that in all cases the levels of success are extremely low — for example, in the study by Michel & Harkins (1985) only 37% of the subjects were able to learn to tie the three proposed knots by just attending demonstrations of how to do it, i.e. by just observing the necessary motor sequence to tie them. This, for us, is an indication that knotting abilities have little (if anything) to do with the accurate internalization of a motor sequence. This suspicion is reinforced by the personal experience of some of us with knot tying (and knot learning), since, at least in our cultural tradition, complex knots are taught not through the description of some hand gestures, but rather by resorting to mnemonic techniques whereby the learner is able to figure out *the number and the direction of the crossings* that make up the knot. These, admittedly scant, observations seem to point in one direction, namely that knot production involves at least a particular case of the more general problem of object recognition — i.e. knot recognition, and concomitantly that spatial representation abilities are also involved.

Now, the literature on visual object recognition is abundant, but it is possible to identify an important trend where it is assumed that object recognition involves something akin to parsing in language. In the case of vision, a common view is to assume that object parsing involves the identification of a number of geometric primitives (often cylinders) — this is, for example, the approach of David Marr (1982) or of Irving Biederman (1987), to cite a couple of relevant examples. Underlying this is the assumption that spatial and object representation is entirely based on part-whole, or mereological, relations. This idea, however, has been subjected to several criticisms on the basis that parthood is insufficient to represent and recognize an object and that mereology needs to be complemented with the notion of connectedness, which is eminently topological. Casati & Varzi (1999), for example, have developed a long and detailed argument in favor of the idea that object and spatial representation is mereo-topological, not just mereological — a proposal that finds some support in certain experimental results suggesting that object recognition often does not involve parsing (Cave & Kosslyn 1993).

How does all this relate to knots? If in spatial representation some topological relations like connectedness are critically involved, it may well then be the case that our claim that the topological theory of Knots may be relevant is not that far fetched after all. Knots, real ones, have no obvious *parts*, just *crossings* in any of the three spatial dimensions and form a connected (even if open) whole, just like mathematical Knots or braids. Our contention was — and is — that it is this information that is important at the time of producing a knot or figuring out one; in other words that to make a knot, one needs first to represent it and to represent it one needs to figure out its topology. We maintain then that it follows that any act of knot tying, untying, learning, or invention is preceded, minimally by a mental act of knot recognition, which involves representing the basic

properties of the knot, i.e. the number and orientation of its crossings.<sup>20</sup> Fine and accurate motor control will only come afterwards, but, we argue, little headway will be made in, for example, knot learning if the focus is just on hand movements and not on the figure itself. Again, this is a debatable issue, and one can (with Lobina 2012: 10) legitimately stick to the behaviorist assumption that “it is very likely that knot-tying would proceed in a trial-and-error fashion”, although, in our opinion, the evidence presented here points in an entirely different direction.

And, so, we have finally come to knot recognition and how it relates to Knot recognition. Let’s start with the latter and proceed slowly until we eventually are able to see how it may be associated with the former.

A very important point to be made in order to understand Knot theory’s concerns with Knot recognition is condensed in Lobina’s following statement: “Knot Theory takes tied knots as its starting assumptions” (p. 75). Which is downright false. Knot theory does not only not take tied Knots as starting assumptions, but it is mainly concerned with proving that there exist other Knots apart from the trivial Knot (the so-called unknot), which is just a closed circle with no crossings. Adams (2004), for example, opens section 1.5 of his book (on page 22) with the following statement: “We have *not yet proved that there is any other knot besides the unknot*. For all we know right now, every projection of a knot [...] could simply be a messy projection of the unknot” (emphasis in the original) — despite this being, of course, “the most basic fact of knot theory”, i.e. the existence of other Knots apart from the unknot. Just as number theory cannot simply assume the existence of prime numbers — this needs to be proved, Knot theory does not simply assume that there are tied Knots — this also calls for a proof. And here is where Knot recognition comes into play.

From the false statement that Knot theory assumes that there are nontrivial Knots, Lobina derives the false conclusion that it is not the case that one of the fundamental problems in Knot theory is determining whether a string is knotted (p. 75). A couple of quotations will suffice, we hope, to settle this. Here’s the first:

A loop in 3-space, called a *knot*, is unknotted or knotted: it is the fundamental problem of knot theory and we call it *Unknotting*.

(Hara *et al.* 2005: 359; emphasis in the original)

Another one:<sup>21</sup>

Determining whether a given knot is trivial or not is one of the historically central questions in topology.

(Agol *et al.* 2005: 3821)

---

<sup>20</sup> This is not to be interpreted as a commitment with the idea that visual representations of knots are mental images or something similar. The characterization in the text is neutral with respect to that. The important factor is that crossings and orientation are represented somehow, and this can be captured by many different representational formats.

<sup>21</sup> There is, by the way, a lurking inconsistency in the way Lobina uses the terms ‘trivial’ and ‘non-trivial’ when referred to Knots. It seems that, for him, ‘trivial’ only applies to those projections of the unknot in which it looks like a circle, with ‘non-trivial’ being applied to those projections in which the unknot appears deformed (see his Figure 1). Another issue that needs to be settled: “The simplest knot of all is just the unknotted circle, which we call the *unknot* or the *trivial knot*” (Adams 2004: 2; emphasis in the original).

And, for good measure, yet another one:<sup>22</sup>

[W]e will say that links have been *classified* if we can solve the *recognition problem*. That is, is there an algorithm that can decide, in a finite amount of time, if a given pair of links are equivalent? Notice that given such an algorithm, we could then enumerate all links [...].

(Hoste 2005: 214; emphasis in the original)

A careful reading of Lobina's text reveals a profound contradiction and, we are afraid, some difficulties in grasping a number of crucial subtleties of Knot theory on his part. Take first his personal account of the UNKNOTTING problem. He writes (p. 74):

The 'unknotting' problem [...] involves specifying an algorithm that can recognize the unknot in a figure like the one found on the right-hand side of Figure 1 (that is, convert the knot on the right-hand side into an unknot).

Firstly, the parenthetical at the end is critical. Note that it presupposes that a deformation of the unknot *is not the unknot*, which it is — the unknot does not cease to be itself in any of its infinitely many different projections (and the Knot appearing on the right-hand side of Figure 1 in Lobina's paper is a projection of the unknot). Secondly, this moreover presupposes that the UNKNOTTING problem just involves transforming a tangled projection of the unknot into an untangled one (a circle) through the successive application of Reidemeister moves, which, yes, are a set of operations that disentangle a Knot without damaging it. But this is *not* the UNKNOTTING problem. It cannot be. The UNKNOTTING problem is *not* an algorithm that can recognize the unknot, but rather an algorithm capable of providing an answer to the question 'is this projection of a Knot a projection of the unknot?' Note that in Lobina's personal interpretation of the problem the answer to this question will always be, trivially, 'yes', because he is assuming that the only projections presented to the algorithm are projections of the unknot and, therefore, the Reidemeister moves will always, sooner or later, convert the projection into a circle.

The point, of course, and this should be clear from the quotations above, is that the algorithm may be presented with a projection of *any* imaginable Knot (the unknot included, of course) and, after the application of the Reidemeister moves, it may turn out that the answer will be 'no'. For this to be possible, however, the algorithm must be able to tell apart the unknot from all other Knots. If it says 'no', the algorithm will certainly not tell us which Knot it is — we will just be certain that it is not the unknot. Note that this is the structure of *any* recognition problem, because recognition (decidability) is defined as the ability to answer 'yes' or 'no' to a specific question concerning some language and, to be able to do that, an algorithm must be equipped with the necessary information to tell apart those elements that belong to the set from those that belong to its complement. When this is not possible, the problem is undecidable, i.e. we may get a 'yes' answer, but we will never get a 'no', with the HALTING problem for

---

<sup>22</sup> Links are composite Knots, which can be decomposed into 'prime Knots'. Therefore our discussion here focuses only on prime Knots, which are links with only one component.

Turing machines being the model for all undecidable problems.<sup>23</sup> The way Lobina presents UNKNOTTING is as if we understood the problem of recognizing, say, the context-free language  $a^n b^n$  as the problem of what a Turing machine (or a push-down automaton for that matter) would do when presented with strings only belonging to that set, which is nonsense.

The reason why UNKNOTTING is so important for Knot theory is because it is precisely the proof that there are other Knots apart from the unknot. It is not an algorithm for listing Knots, of course, nothing like this seems to be forthcoming in the near future, just like no algorithm for calculating all prime numbers will be forthcoming either, although at least we know there are other primes beyond 2.

Finally, note that Lobina's statement that "Knot Theory takes tied knots as its starting assumptions" (which it doesn't) is simply contradictory with the idea that UNKNOTTING merely involves disentangling projections of the unknot. If the existence of nontrivial Knots is assumed, why should the task of "working out the formal equivalence of two knots" (p. 74) be just concerned with showing that two projections of the *same* Knot are equivalent? Clearly because UNKNOTTING does not involve working out the formal equivalence of two knots, but rather telling apart the unknot and any Knot projection within the same equivalence class from other Knot projections not in this class. To find a parallelism, UNKNOTTING is as if we were asking 'is  $x$ ,  $x \in \mathbb{Q}$ , in the same equivalence class as  $y$ ,  $y \in \mathbb{Q}$ ?' and we fixed  $y = \frac{1}{2}$ . Then, with input  $x = \frac{2}{4}$  the answer will be 'yes' and with input  $x = \frac{2}{3}$  the answer will be 'no'. Actually, this formulation of the recognition of equivalence classes in rational numbers comes closer to the other Knot recognition problem analyzed in Hass *et al.* (1999), the paper dealing with the complexity of Knot recognition problems we cited in Balari *et al.* (2011). This problem, which we will refer to as GENUS, is a generalization of UNKNOTTING in the sense that it can be parameterized just like the case of rational equivalence classes by fixing a value for  $y$  and then testing whether some  $x$  is in the same equivalence class as  $y$ . Note that this is precisely the kind of recognition problem to which Hoste (2005) is referring in the quotation above.

To see what GENUS does, we will first have to explain what the genus of a Knot is. Perhaps the best way to do this is with a picture like the one we have in Figure 2.

---

<sup>23</sup> The reason being, of course, that the complement of HALTING is neither recursive nor recursively enumerable, and decidability implies that if we have a decision algorithm for a set, then we automatically have one for its complement.

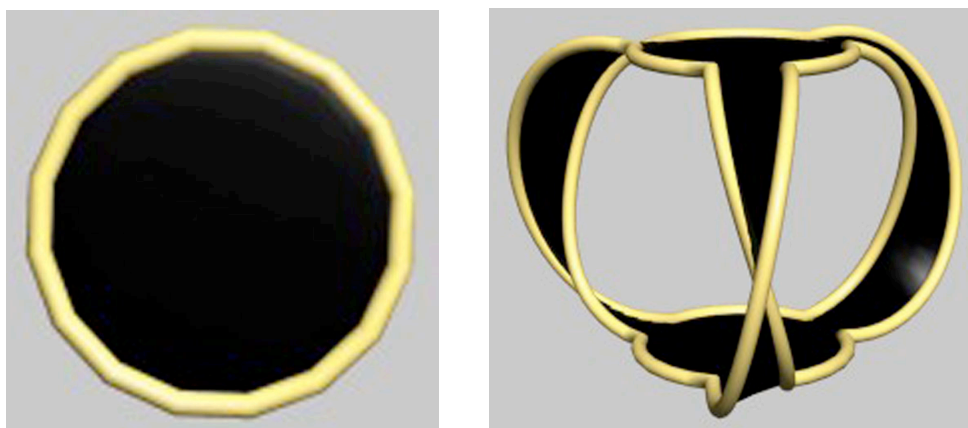

Figure 2: The unknot (left) and the trefoil knot (right) as boundaries of a Seifert surface. The strands of the Knots appear in yellow and the surface is black. (The two images were generated with the *SeifertView* free software developed by Jarke J. van Wijk, Technische Universiteit Eindhoven.)

As can be seen in the two images of the figure, Knots can be conceptualized as the boundaries of a continuous surface (a Seifert surface) such that the perimeter of the surface is entirely delineated by the strands of the Knot. Observe that in the case of the unknot, the object made up of the Knot plus the surface (Figure 2, left) is something like a drum or a tambourine — the surface has no holes in it. In the case of the trefoil Knot, however, the surface appears perforated (Figure 2, right). It is not immediately obvious from the direct inspection of the image, but the number of holes in the surface is in this case exactly 1.<sup>24</sup> This is the genus of a Knot: The number of holes in the Seifert surface defined by its strands. Note that the genus of the unknot is 0 and that the genus of the trefoil Knot is 1. The genus of a Knot is an indirect indication of its degree of knottedness and, hence, we can formulate a recognition problem in which our question is: ‘Is the genus of this Knot equal to (smaller than, greater than)  $g$ ,  $g$  an integer?’ This is the GENUS problem as formulated in Hass *et al.* (1999) and, perhaps more clearly, in Agol *et al.* (2002, 2005). UNKNOTTING is then a particular case of GENUS for the question: ‘Is the genus of this Knot equal to 0?’

Now that we have a proper definition of the two Knot recognition problems, we can turn to their complexity results. Hass *et al.* (1999) located UNKNOTTING in **NP** and GENUS in **PSPACE**. This is already an indication that Knot recognition, in its simplest case, is a language (remember that problems are languages) falling within a complexity space closer to that of natural language, since, according to Ristad (1993), NATURAL LANGUAGE is **NP**-complete. It could even be harder, and equivalent to context-sensitive recognition, given the **PSPACE** result for GENUS. In a later study, Agol *et al.* (2002, 2005) reclassified GENUS as **NP**-complete, i.e. exactly in the same complexity class as NATURAL LANGUAGE, while Kuperberg (2011) has recently reclassified UNKNOTTING in **NP**  $\cap$  **coNP**, reducing thus its complexity.

<sup>24</sup> The trick is that it can be demonstrated that the surface is equivalent to a torus (a donut), a surface with a single hole. Other knots will define surfaces equivalent to two or more joined tori, while the unknot defines a surface that is equivalent to a sphere, which has genus 0 (no holes); see Adams (2004: chap. 4).

The question remains open. Newer and more accurate complexity results may be forthcoming for Knot recognition, but it doesn't seem likely that these will locate it in an entirely different complexity space. The computational complexity of natural language and that of Knot recognition are equivalent or very close to each other. These are uncontroversial facts, "not subject to rational debate". What is debatable, of course, is the relevance of Knot recognition complexity results in the assessment of the complexity of knot recognition. It could be the case that knot recognition in humans is a totally different thing from Knot recognition, that it doesn't have anything to do with topology and the identification of crossings in a knot and their orientation, whatever. We are open to discuss this. It's a hypothesis, but a hypothesis that is as informed as it could possibly be given the state of the art of our knowledge of the issues at stake here. Nothing, anyway, that Lobina has been able to really call into question in his paper. And, in the end, it may well be the case that we are on the right track after all.

In his paper, Lobina cites an article by Alan Turing that was unknown to us (Turing 1954), where Turing presents a variety of the Knot recognition problem as one of the challenging puzzles in mathematics. To illustrate the problem, Turing describes a Knot and a method for representing Knots that allows him to reduce a 3D object to a string of symbols. Turing's technique essentially consists of selecting a number of points in a system of Cartesian coordinates and joining them with segments in order to get a closed, connected loop. In addition, Turing encodes the directionality of each segment with a letter, such that a single step from  $n$  to  $n+1$  in  $X$  is encoded by an **a**, a step from  $n$  to  $n-1$  in  $X$  is encoded by a **d**, and so on with the other two dimensions, as shown in Figure 3:

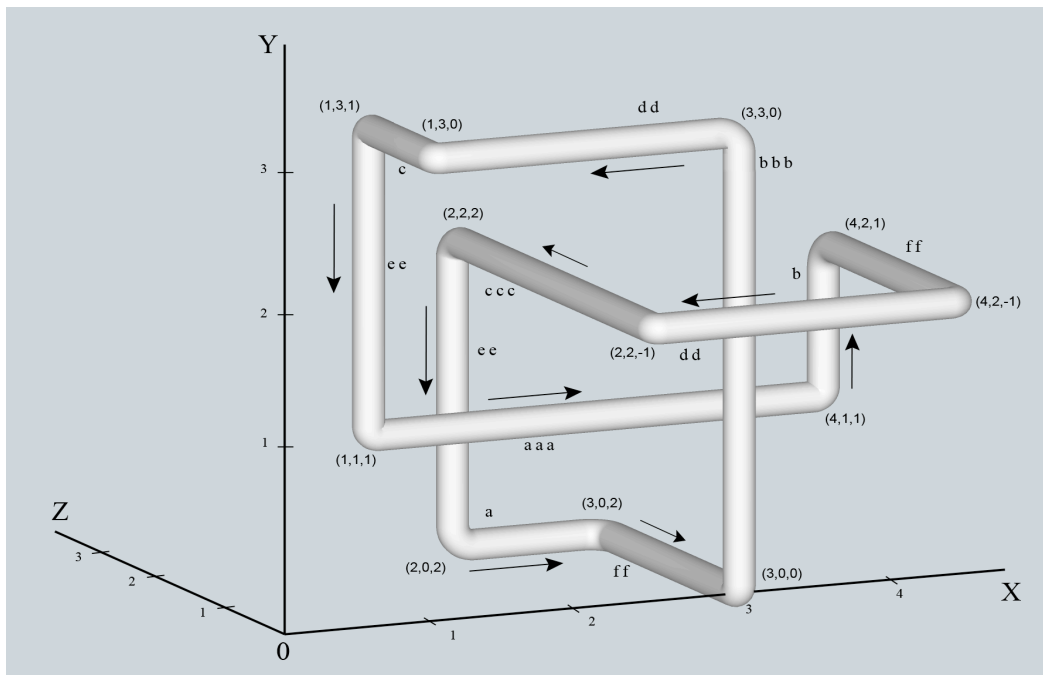

Figure 3: A representation of the trefoil knot in a system of Cartesian coordinates. (Adapted from figure (1b), p. 586, of *The Essential Turing*, B. Jack Copeland (ed.), Oxford University Press.)



With this representation system, the trefoil Knot can be encoded with the string in (1) and Knot recognition is reduced to a language recognition problem as required by computational complexity theory:

$$(1) \quad a_i a_j a_k b_l f_m f_n d_i d_j c_m c_n c_p e_l e_q a_r f_p f_s b_q b_t b_u d_k d_r c_s e_t e_u$$

Note that the basic constraint seems to be that the number of *as* is equal to the number of *ds*, the number of *bs* is equal to the number of *es*, and the number of *cs* is equal to the number of *fs*. There are probably others, since it is not clear that any arrangement of these symbols always describes a Knot. Whatever the solution, this mode of representation would open a way to investigate more thoroughly the question of Knot representation and recognition, which as we contended in our earlier papers — and we have come to corroborate here with Turing’s system — is not a trivial task. Thus, and depending on what the exact characterization of this ‘Knot language’ is, we seem to have here a language like the following:

$$(2) \quad K = \{a^n c^m e^p b^n d^m f^p\}$$

Assuming that the only constraint to adequately describing a Knot is that the number of positive steps in one dimension equals the number of negative steps in the same dimension, but that all positive and negative steps in all three dimensions need not be equal. This is a mildly-context sensitive language with three cross-serial dependencies. However, if the number of positive and negative steps must be the same in all dimensions, then we would seem to have a six-column language like the following:

$$(3) \quad K = \{a^n c^n e^n b^n d^n f^n\}$$

Which is indexed, and probably equivalent to the triple-copy language in (4), all beyond the power of mildly context-sensitive systems (Radzinski 1991) and, hence possibly residing in a higher complexity class than natural language.

$$(4) \quad K = \{www \mid w \in (a+b)^*\}$$

Be this as it may, Turing’s is a rather clear, and perhaps more intuitive, method for representing Knots that easily captures their two basic properties. Also, it makes their formal complexity more perspicuous, as can be seen from the quick analysis we have just presented.<sup>25</sup> This analysis, even if a rough one, demonstrates that Knots (and knots) are complex objects, but no too complex, perhaps sitting in a region of complexity space similar or not too far away from that of language, as it was originally conjectured by Camps & Uriagereka (2006).

---

<sup>25</sup> Turing’s method is not too different from the Dowker notation for representing Knots, since both give us an indication of the number of crossings. In the Dowker notation each crossing is represented by an ordered pair of integers,  $(x, y)$ , where  $x$  is odd and  $y$  is even, such that the number of pairs (or an ordered list of even numbers) equals the number of crossings in the knot. In this notation, however, it is harder to ‘read’ the orientation of the crossings than in Turing’s, where it can be immediately identified by the change from one symbol to another in the string.

On the whole, and considering the different kinds of data we have presented here, it seems likely that natural computational systems, knots, and language do not define such a bizarre love triangle after all as pretended by Lobina. Paraphrasing Bernard Sumner *et al.*'s (1986) lyrics, we still feel compelled to sing: "If you say the words that I can't say, maybe it's because you can tie the knots that I can't tie". Why should we refrain from investigating it?

Camps & Uriagereka (2006) opened their conclusions section with the following words (p. 63; our emphasis):

Our conclusion within this paper is not subject to rational debate: knots are *not describable* by any generative procedure that does not have enough operational memory to count as context-sensitive [...].

Meaning, of course, that the inherent complexity of knots is an uncontroversial fact. It's there. And any attempt to model human knot-tying abilities will have to take it into account. Just like the results concerning the inherent structural and computational complexity of natural language are there and must serve to drive our research in biolinguistics. This was Camps & Uriagereka's (2006) message and it is our message here.

A fragment taken from the quotation above appears to be one of Lobina's favorites, especially when dropped here and there out of context, or even in the wrong context. It is however surprising to what an extent has Lobina come to believe his own interpretation of the fragment and how faithfully he applies it in his criticisms. A theory, like a knot, is a difficult thing to construct — and like a knot is easier to cut than to entangle, a theory too is easier to trash than to refute. Some people spend their lives telling others that "they don't understand". It would be useful to see what it is that the critics understand, and how that understanding has solutions of any sort to the real problems that science poses, or even how these dynamics allow us to turn absolute mysteries into workable problems. Nothing in Lobina advances our understanding of the problems that were at stake here. It is a classic instance of formal bullying, whereby tools that ought to help us gain insight over our subject matter manage to turn into rhetorical cilices for no discernible purpose other than posturing. It is sad to see how this sort of sophistic logic is often sold as sophisticated reasoning.

## References

- Adams, Colin. 2004. *The Knot Book. An Elementary Introduction to the Mathematical Theory of Knots*. Providence, RI: American Mathematical Society.
- Agol, Ian, Joel Hass & William Thurston. 2002. 3-manifold knot genus is NP-complete. In *Proceedings of the Thirty-fourth Annual ACM Symposium on Theory of Computing*, 761–766. New York: ACM Press.
- Agol, Ian, Joel Hass & William Thurston. 2005. The computational complexity of knot genus and spanning area. *Transactions of the American Mathematical Society* 358, 3821–3850.
- Alle, Henrik & Jörg R. P. Geiger. 2006. Combined analog and action potential coding in hippocampal mossy fibers. *Science* 311, 1290–1293.

- Baddeley, Alan. 2007. *Working Memory, Thought, and Action*. Oxford: Oxford University Press.
- Balari, Sergio, Antonio Benítez-Burraco, Marta Camps, Víctor M. Longa & Guillermo Lorenzo. 2010. La importancia de ser moderno. Problemas de método e ideología en el debate sobre la cognición y la conducta de los neandertales. *Ludus Vitalis* XVIII(34), 143–170.
- Balari, Sergio, Antonio Benítez-Burraco, Marta Camps, Víctor M. Longa, Guillermo Lorenzo & Juan Uriagereka. 2008. ¿Homo loquens neanderthalensis? En torno a las capacidades simbólicas y lingüísticas del neandertal. *Munibe Antropología–Arkeologia* 59, 3–24.
- Balari, Sergio, Antonio Benítez-Burraco, Marta Camps, Víctor M. Longa, Guillermo Lorenzo & Juan Uriagereka. 2011. The archaeological record speaks: Bridging anthropology and linguistics. *International Journal of Evolutionary Biology* 2011, doi:10.4061/2011/382679.
- Balari, Sergio & Guillermo Lorenzo. 2008. Pere Alberch's developmental morphospaces and the evolution of cognition. *Biological Theory* 3, 297–304.
- Balari, Sergio & Guillermo Lorenzo. 2009. Computational phenotypes: Where the theory of computation meets Evo-Devo. *Biolinguistics* 3, 2–60.
- Balari, Sergio & Guillermo Lorenzo. To appear. *Computational Phenotypes. Towards an Evolutionary Developmental Biolinguistics* (Oxford Studies in Biolinguistics). Oxford: Oxford University Press.
- Benítez-Burraco, Antonio, Víctor M. Longa, Guillermo Lorenzo & Juan Uriagereka. 2008. Also sprach Neanderthalis... or did she?. *Biolinguistics* 2, 225–232.
- Biederman, Irving. 1987. Recognition-by-Components: A theory of human image understanding. *Psychological Review* 94, 115–147.
- Brentari Diane (ed.) 2010. *Sign Languages*. New York: Cambridge University Press.
- Camps, Marta & Juan Uriagereka. 2006. The Gordian Knot of linguistic fossils. In Joana Rosselló & Jesús Martín (eds.), *The Biolinguistic Turn. Issues on Language and Biology*, 34–65. Barcelona: PPU.
- Casati, Roberto & Achille C. Varzi. 1999. *Parts and Places. The Structures of Spatial Representation*. Cambridge, MA: MIT Press.
- Cave, Carolyn Baker & Stephen M. Kosslyn. 1993. The role of parts and spatial relations in object identification. *Perception* 22, 229–248.
- Cheng, Hsiang-Chun, Hung-Yi Chen, Chia-Liang Tsai, Yung-Jung Chen & Ron-Ju Cherng. 2009. Comorbidity of motor and language impairments in preschool children of Taiwan. *Research in Developmental Disabilities* 30, 1054–1061.
- Chomsky, Noam. 1956. On the limits of finite-state description. *Quarterly Progress Report* 48, 116–118.
- Chomsky, Noam. 1957. *Syntactic Structures*. The Hague: Mouton.
- Chomsky, Noam. 1959. On certain formal properties of grammars. *Information and Control* 2, 137–168.
- Chomsky, Noam. 1963. Formal properties of grammars. In R. Duncan Luce, Robert R. Bush & Eugene Galanter (eds.), *Handbook of Mathematical Psychology*, vol. II, 323–418. New York, NY: John Wiley.

- Chomsky, Noam. 2007. Approaching UG from below. In Uli Sauerland & Hans-Martin Gärtner (eds.), *Interfaces + Recursion = Language? Chomsky's Minimalism and the View from Syntax–Semantics*, 1–29. Berlin: de Gruyter.
- Chomsky, Noam. 2010. Some simple evo devo theses: How true might they be for language. In Richard K. Larson, Viviane Déprez & Hiroko Yamakido (eds.), *The Evolution of Language: Biolinguistic Perspectives*, 45–62. Cambridge: Cambridge University Press.
- Coolidge, Frederick L. & Thomas Wynn. 2004. A cognitive and neuropsychological perspective on the Châtelperronian. *Journal of Anthropological Research* 60, 55–73.
- Del Vecchio, Domitilla, Richard M. Murray & Pietro Perona. 2003. Decomposition of human motion into dynamics-based primitives with application to drawing tasks. *Automatica* 39, 2085–2098.
- Devitt, Michael. 2006. *Ignorance of Language*. Oxford: Oxford University Press.
- Dipietro, Laura, Hermano I. Krebs, Susan E. Fasoli, Bruce T. Volpe & Neville Hogan. 2009. Submovement changes characterize generalization of motor recovery after stroke. *Cortex* 45, 318–324.
- Earley, Jay. 1970. An efficient context-free parsing algorithm. *Communications of the ACM* 13, 94–102.
- Eden, Guinevere F., Frank B. Wood & John F. Stein. 2003. Clock drawing in developmental dyslexia. *Journal of Learning Disabilities* 36, 216–228.
- Fisher, Simon & Constance Scharff. 2009. *FOXP2* as a molecular window into speech and language. *Trends in Genetics* 25, 166–177.
- Fitch, W. Tecumseh & Marc D. Hauser. 2004. Computational constraints on syntactic processing in nonhuman primates. *Science* 303, 377–380.
- Flash, Tamar & Binyamin Hochner. 2005. Motor primitives in vertebrates and invertebrates. *Current Opinion in Neurobiology* 15, 660–666.
- Fodor, Jerry A. 1975. *The Language of Thought*. New York: Thomas & Crowell.
- Fodor, Jerry A. & Massimo Piattelli-Palmarini. 2010. *What Darwin Got Wrong*. New York: Farrar, Straus and Giroux.
- Fujita, Eriko, Yuko Tanabe, Akira Shiota, Masatsugu Ueda, Kiyotaka Suwa, Mariko Y. Momoi & Takashi Momoi. 2008. Ultrasonic vocalization impairment of *Foxp2* (R552H) knockin mice related to speech-language disorder and abnormality of Purkinje cells. *Proceedings of the National Academy of Sciences USA* 105, 3117–3122.
- Fung, Victor S., Morris, John G., Jonathan Leicester, Y. S. Soo & Llewelyn Davies. 1997. Clonic perseveration following thalamofrontal disconnection: A distinctive movement disorder. *Movement Disorders* 12, 378–385.
- Gentner, Timothy Q., Kimberly M. Fenn, Daniel Margoliash & Howard C. Nusbaum. 2006. Recursive syntactic pattern learning in songbirds. *Nature* 440, 1204–1207.
- Gopnik, Myrna. 1990. Feature-blind grammar and dysphasia. *Nature* 344: 715.
- Grossman, Murray G., S. Carvell, S. Gollomp, M. B. Stern, G. Vernon & H. I. Hurtig. 1991. Sentence comprehension and praxis deficits in Parkinson's disease. *Neurology* 41, 1620–1628.
- Gusella, James F. & Marcy E. MacDonald. 2006. Huntington's disease: seeing the pathogenic process through a genetic lens. *Trends in Biochemical Sciences* 31,

- 533–540.
- Hara, Masao, Seiichi Tani & Makoto Yamamoto. 2005. UNKNOTTING is in  $\mathbf{AM} \cap \mathbf{co-AM}$ . *16<sup>th</sup> ACM-SIAM Symposium on Discrete Algorithms (SODA 2005)*, 359–364, Vancouver, BC.
- Hass, Joel, Jeffrey C. Lagarias & Nicholas Pippenger. 1999. The computational complexity of knots and link problems. *Journal of the ACM* 46, 185–211.
- Hauser, Marc D., Noam Chomsky & W. Tecumseh Fitch. 2002. The faculty of language: What is it, who has it, and how did it evolve? *Science* 298, 1569–1579.
- Heijningen, Caroline A. A. van, Jos de Visser, Willem Zuidema & Carel ten Cate. 2009. Simple rules can explain discrimination of putative recursive syntactic structures by a songbird species. *Proceedings of the National Academy of Sciences USA* 106, 20538–20543.
- Herzfeld, Chris & Dominique Lestel. 2005. Knot tying in great apes: Etho-ethnology of an unusual tool behavior. *Social Science Information* 44, 621–653.
- Hinzen, Wolfram. 2006. *Mind Design and Minimal Syntax*. Oxford: Oxford University Press.
- Hopcroft, John E. & Jeffrey D. Ullman. 1979. *Introduction to Automata Theory, Languages, and Computation*. Reading, MA: Addison-Wesley.
- Hoste, Jim. 2005. The enumeration and classification of knots and links. In William W. Menasco & Morwen B. Thistlethwaite (eds.), *The Handbook of Knot Theory*, 209–232. Amsterdam: Elsevier.
- Hudson, Kerry D. & Emily K. Farran. 2010. Drawing the line: Drawing and construction strategies for simple and complex figures in Williams syndrome and typical development. *British Journal of Developmental Psychology* 29, 687–706.
- Iverson, Jana M. & Barbara A. Braddock. 2011. Gesture and motor skill in relation to language in children with language impairment. *Journal of Speech, Language, and Hearing Research* 54, 72–86.
- Karmiloff-Smith, Annette. 2006. Williams Syndrome. In Keith Brown (ed.), *Encyclopedia of Language and Linguistics*, vol. 13, 585–589, Oxford: Elsevier.
- Khabbaz, Nabil A. 1974. A geometric hierarchy of languages. *Journal of Computer and System Sciences* 8, 142–157.
- Kuperberg, Greg. 2011. Knottedness is in NP, modulo GRH. [<http://arxiv.org/abs/1112.0845>] (4 February 2012).
- Lewis, Harry R. & Christos H. Papadimitriou. 1981. *Elements of the Theory of Computation*. Englewood Cliffs, NJ: Prentice-Hall.
- Lieberman, Philip. 2000. *Human Language and Our Reptilian Brain. The Subcortical Bases of Speech, Syntax and Thought*. Cambridge, MA: Harvard University Press.
- Lieberman, Philip. 2002. On the nature and evolution of the neural bases of human language. *American Journal of Physical Anthropology* 45, 36–62.
- Lieberman, Philip. 2006. *Toward an Evolutionary Biology of Language*. Cambridge, MA: Harvard University Press.
- Liégeois, Frédérique, Torsten Baldeweg, Alan Connelly, David G. Gadian, Mortimer Mishkin & Faraneh Vargha-Khadem. 2003. Language fMRI ab-

- normalities associated with *FOXP2* gene mutation. *Nature Neuroscience* 6, 1230–1237.
- Lipowska, Malgorzata, Ewa Czaplewska & Anna Wysocka. 2011. Visuospatial deficits of dyslexic children. *Medical Science Monitor* 17, CR216–221.
- Lobina, David. 2012. Conceptual structure and the emergence of the language faculty: Much ado about knotting. Ms., Tarragona: Universitat Rovira i Virgili. *LingBuzz*, <http://ling.auf.net/lingBuzz/001397>.
- MacSweeney, Mairéad, Cheryl M. Capek, Ruth Campbell & Bencie Woll. 2008. The signing brain: the neurobiology of sign language. *Trends in Cognitive Sciences* 12, 432–440.
- Makuuchi, Michiru. 2010. fMRI studies on drawing revealed two new neural correlates that coincide with the language network. *Cortex* 46, 268–269.
- Makuuchi, Michiru, Tatsuro Kaminaga & Morihiko Sugishita. 2003. Both parietal lobes are involved in drawing: a functional MRI study and implications for constructional apraxia. *Cognitive Brain Research* 16, 338–347.
- Marcus, Gary & Simon E. Fisher. 2003. *FOXP2* in focus: what can genes tell us about speech and language? *Trends in Cognitive Sciences* 7, 257–262.
- Marr, David. 1982. *Vision*. San Francisco, CA: Freeman.
- Michel, George F. & Debra A. Harkins. 1985. Concordance of handedness between teacher and student facilitates learning manual skills. *Journal of Human Evolution* 14, 597–601.
- Minelli, Alessandro. 2011. A principle of developmental inertia. In Benedikt Hallgrímsson & Brian K. Hall (eds.), *Epigenetics. Linking Genotype and Phenotype in Development and Evolution*, 116–133. Berkeley, CA: University of California Press.
- Murray, Laura L. 2000. Spoken language production in Huntington's and Parkinson's diseases. *Journal of Speech, Language, and Hearing Research* 43, 1350–1366.
- O'Donnell, Timothy J., Marc D. Hauser & W. Tecumseh Fitch. 2005. Using mathematical models of language experimentally. *Trends in Cognitive Sciences* 9, 284–289.
- Papadimitriou, Christos H. 1994. *Computational Complexity*. Reading, MA: Addison-Wesley.
- Pavlidou, Elpis V., M. Louise Kelly & Joanne M. Williams. 2010. Do children with developmental dyslexia have impairments in implicit learning? *Dyslexia* 16, 143–161.
- Perruchet, Pierre & Arnaud Rey. 2005. Does the mastery of center-embedded linguistic structures distinguish humans from non-humans?. *Psychonomic Bulletin and Review* 12, 307–313.
- Petersson, Karl Magnus, Vasiliki Folia & Peter Hagoort. 2010. What artificial grammar learning reveals about the neurobiology of syntax. *Brain and Language*, doi 10.1016/j.bandl.2010.08.003.
- Radzinski, Daniel. 1991. Chinese number-names, Tree Adjoining Languages, and mild context-sensitivity. *Computational Linguistics* 17, 277–299.
- Rechetnikov, Rouslan P. & Kinsuk Maitra. 2009. Motor impairments in children associated with impairments of speech or language: A meta-analytic review of research literature. *The American Journal of Occupational Therapy* 63, 255–

- 263.
- Ristad, Eric Sven. 1993. *The Language Complexity Game*. Cambridge, MA: The MIT Press.
- Rogers, James & Marc D. Hauser. 2010. The use of formal language theory in studies of artificial language learning: A proposal for distinguishing the differences between human and nonhuman animal learners. In Harry van der Hulst (ed.), *Recursion and Human Language*, 213–232. Amsterdam: Mouton de Gruyter.
- Rogers, James & Geoffrey K. Pullum. 2011. Aural pattern recognition experiments and the Subregular Hierarchy. *Journal of Logic, Language and Information* 20, 329–342.
- Sarpeshkar, Rahul. 1998. Analog versus digital: Extrapolating from electronics to neurobiology. *Neural Computation* 10, 1601–1638.
- Sarpeshkar, Rahul. 2009. Neuromorphic and biomorphic engineering systems. In *McGraw-Hill Yearbook of Science & Technology 2009*, 250–252. New York: McGraw-Hill.
- Shriberg, Lawrence D., Kirrie J. Ballard, J. Bruce Tomblin, Joseph R. Duffy, Katharine H. Odell & Charles A. Williams. 2006. Speech, prosody, and voice characteristics of a mother and daughter with a 7,13 translocation affecting *FOXP2*. *Journal of Speech, Language, and Hearing Research* 49, 500–525.
- Shu, Yousheng, Andrea Hasenstaub, Álvaro Duque, Yuguo Yo & David McCormick. 2006. Modulation of intracortical synaptic potentials by presynaptic somatic membrane potential. *Nature* 441, 761–765.
- Shu, Weiguo, Julie Y. Cho, Yuhui Jiang, Minhua Zhang, Donald Weisz, Gregory A. Elder, James Schmeidler, Rita De Gasperi, Miguel A. Gama Sosa, Donald Rabidou, Anthony C. Santucci, Daniel Perl, Edward Morrissey & Joseph D. Buxbaum. 2005. Altered ultrasonic vocalization in mice with a disruption in the *Foxp2* gene. *Proceedings of the National Academy of Sciences USA* 102, 9643–9648.
- Striedter, Georg F. 2005. *Principles of Brain Evolution*. Sunderland, MA: Sinauer.
- Sumner, Bernard, Gillian Gilbert, Peter Hook & Stephen Morris. 1986. Bizarre love triangle. In *New Order, Brotherhood* (FACT 150), side two, track 1. Manchester: Factory.
- Surmeier, D. James, Jaime N. Guzmán, Javier Sánchez-Padilla & Joshua A. Goldberg. 2010. What causes the death of dopaminergic neurons in Parkinson's disease? *Progress in Brain Research* 183, 59–77.
- Tomalin, Marcus. 2007. Reconsidering recursion in syntactic theory. *Lingua* 117, 1784–1800.
- Tomalin, Marcus. 2011. Syntactic structures and recursive devices: A legacy of imprecision. *Journal of Logic, Language and Information* 20, 297–315.
- Tracy, Joseph, Adam Flandrers, Saussan Madi, Joseph Laskas, Eve Stoddard, Ayis Pyrros, Peter Natale & Nicole DelVecchio. 2003. Regional brain activation associated with different performance patterns during learning of a complex motor skill. *Cerebral Cortex* 13, 904–910.
- Troyer, Angela K., Sandra E. Black, Maria L. Armilio & Morris Moscovitch. 2004. Cognitive and motor functioning in a patient with selective infarction of the

- left basal ganglia: evidence for decreased non-routine response selection and performance. *Neuropsychologia* 42, 902–911.
- Turing, Alan M. 1954. Solvable and unsolvable problems. In B. Jack Copeland (ed.), *The Essential Turing*, 576–595. Oxford: Oxford University Press.
- Ullman, Michael T. 2001. The declarative/procedural model of lexicon and grammar. *Journal of Psycholinguistic Research* 30, 37–69.
- Ullman, Michael T. 2004. Contributions of memory circuits to language: the declarative/procedural model. *Cognition* 92, 231–270.
- Vargha-Khadem, Faraneh, Kate E. Watkins, Katie J. Alcock, Paul Fletcher & Richard E. Passingham. 1995. Praxic and nonverbal cognitive deficits in a large family with a genetically transmitted speech and language disorder. *Proceedings of the National Academy of Sciences USA* 92, 930–933.
- Vargha-Khadem, Faraneh, Kate E. Watkins, C. J. Price, John Ashburner, Katie J. Alcock, Alan Connelly, Richard S. J. Frackowiak, Karl J. Friston, M. E. Pembrey, Mortimer Mishkin David G. Gadian & Richard E. Passingham. 1998. Neural basis of an inherited speech and language disorder. *Proceedings of the National Academy of Sciences USA* 95, 12695–12700.
- Vargha-Khadem, Faraneh., David G. Gadian, Andrew Copp & Mortimer Mishkin. 2005. *FOXP2* and the neuroanatomy of speech and language. *Nature Reviews Neuroscience* 6, 131–138.
- Vicari, Stefano, A. Finzi, Deny Menghini, Luigi Marotta, S. Baldi & Laura Petrosini. 2005. Do children with developmental dyslexia have an implicit learning deficit? *Journal of Neurology, Neurosurgery & Psychiatry* 76, 1392–1397.
- Vijay-Shanker, K. & David J. Weir. 1994. The equivalence of four extensions of context-free grammars. *Mathematical Systems Theory* 27, 511–546.
- Waddington, Conrad H. 1957. *The Strategy of the Genes*. London: Allen and Unwin.
- Watkins, Kate E., Faraneh Vargha-Khadem, John Ashburner, Richard E. Passingham, Alan Connelly, Karl J. Friston, Richard S. J. Frackowiak, Mortimer Miskin & David G. Gadian. 2002a. MRI analysis of an inherited speech and language disorder: structural brain abnormalities. *Brain* 125, 465–478.
- Watkins, Kate E., Nina F. Dronkers & Faraneh Vargha-Khadem. 2002b. Behavioural analysis of an inherited speech and language disorder: Comparison with acquired aphasia. *Brain* 125, 452–464.
- Webster, Richard I., Annette Majnemer, Robert W. Platt & Michael I. Shevell. 2005. Motor function at school age in children with a preschool diagnosis of developmental language impairment. *Journal of Pediatrics* 146, 80–85.
- Weir, David J. 1992. A geometric hierarchy beyond context-free languages. *Theoretical Computer Science* 104, 235–261.
- Weir, David J. 1994. Linear iterated pushdowns. *Computational Intelligence* 10, 431–439.
- Williams, George C. 1966. *Adaptation and Natural Selection*. Oxford: Oxford University Press.
- Wynn, Thomas & Frederick L. Coolidge. 2011. The implications of the working memory model for the evolution of modern cognition. *International Journal of Evolutionary Biology*, doi:10.4061/2011/741357.



Zylberberg, Ariel, Stanislas Dehaene, Pieter R. Roelfsema & Mariano Sigman.  
2011. The human Turing machine: A neural framework for mental programs. *Trends in Cognitive Sciences* 15, 293–300.

Sergio Balari  
Universitat Autònoma de Barcelona  
& Centre de Lingüística Teòrica  
Departament de Filologia Catalana  
Edifici B, Campus UAB  
08193 Bellaterra (Barcelona)  
Spain  
[Sergi.Balari@uab.cat](mailto:Sergi.Balari@uab.cat)

Antonio Benítez-Burraco  
Universidad de Huelva  
Departamento de Filología Española  
y sus Didácticas  
Campus El Carmen  
21071 Huelva  
Spain  
[antonio.benitez@dfesp.uhu.es](mailto:antonio.benitez@dfesp.uhu.es)

Marta Camps  
George Washington University  
Department of Anthropology  
Center for the Advanced  
Study of Human Paleobiology  
Washington DC 20052  
USA  
[mcamps@gwu.es](mailto:mcamps@gwu.es)

Víctor M. Longa  
Universidade de Santiago de Compostela  
Departamento de Literatura Española, Teoría  
da Literatura e Lingüística Xeral  
Campus Norte  
15782 Santiago de Compostela  
Spain  
[victormanuel.longa@usc.es](mailto:victormanuel.longa@usc.es)

Guillermo Lorenzo  
Universidad de Oviedo  
Departamento de Filología Española  
Facultad de Filosofía y Letras, Campus El Milán  
33011 Oviedo  
Spain  
[glorenzo@uniovi.es](mailto:glorenzo@uniovi.es)

## The Present of UG

Aritz Irurtzun

Universal Grammar (UG) has been one of the core ideas of generative grammar since its inception. Obviously, the idea of a UG is not an innovation of generative grammar; in fact, it has long roots in the Western philosophical tradition that extend to the High Middle Ages (cf. Eco 1993, Covington 2009). However, there is no doubt that UG has experienced a new vindication and popularity since the outset of generative grammar and the focus that generative grammar put on descriptive and explanatory adequacy (cf. Chomsky 1965, 1966). UG is the key component that explains at the same time both the linguistic universals (the constrained variability observable among natural languages), and the path of language acquisition in infants. Over the last decades, there has been a substantive amount of research and advancement in the exploration of the nature of UG, its nature and species specificity. This type of research has been conducted from very different grounds: comparative linguistics and parametric linguistic variation (see, among many others, the works of Borer 1984, Baker 1996, 2005, Rizzi 2000, or Boeckx 2011), natural language acquisition and the Language Acquisition Device (cf., *inter alia*, Hornstein & Lightfoot 1981, Crain & Pietroski 2001, Yang 2003, Hale & Reiss 2003, or the general overview in Ayoun 2003), linguistic diachrony and change (cf. Lightfoot 1993, Niyogi 2006, Roberts 2007), and artificial language learning in humans (cf. works like Smith & Tsimpli 1995, Musso *et al.* 2003) and non-humans (cf. Premack 1980 and the debate in Piattelli-Palmarini 1980, Wallman 1992 for a critical review, and Hauser *et al.* 2002 for an important contribution demarcating the nature of UG).

In fact, one of the virtues of this general approach is that UG is sought as the unique *explanans* for the *explananda* of parametric variation, language change and language acquisition; the three are different faces of the same problem: How does the child get from its initial state to a steady state of linguistic knowledge? Language change is intimately related the acquisition process, which is mediated by the Language Acquisition Device (i.e. UG), which constrains the parametric options available for natural languages. However, UG is still a disputed notion, and scholars of different orientations argue that we could (and should) dispense with it; see, for instance, Elman *et al.* (2006), the Boden–Chomsky discussion (Boden 2006, Chomsky 2007, Boden 2007), or the recent critique of linguistic nativism in Clark & Lappin (2011).

Many of these topics were discussed at the conference entitled *The Past and*

---

I would like to thank the organizers of the conference as well as the projects GIC07/144-IT-210-07 (Basque Gov.), 2011 JSH2 004 1 and TSABL (French ANR), and FFI2011-29218 and FFI2008-04789/FILO (Spanish Ministry) as well as the UFI HiTeDi (UFI11/14, UPV/EHU). Many thanks also to Cedric Boeckx.



*Future of UG* (15–18 December 2011), wonderfully organized by Wolfram Hinzen, Alex Drummond, Uli Reichard, and Michelle Sheehan from the Department of Philosophy at Durham University with the financial support of the British Academy (grant CS110386), the AHRC & DFG (grant AH/H50009X/1) and Oxford University Press, in which I had the great fortune to participate. As said in the conference booklet, the main goal of this conference was to create “an international, interdisciplinary forum for assessing and re-directing research on Universal Grammar and the biological foundations of language, bringing together linguists, psychologists, philosophers, and biologists”. I have to stress that the conference was very well equipped to approach that goal, for it counted with the participation of very prominent scholars, specialists in a wide variety of topics that ranged from analytic philosophy to neuro-imaging, from psychiatry to paleontology, and, of course, different areas of linguistics.

The gathering started with Oxford psychiatrist **Tim J. Crow**'s public lecture. Crow provided an overview, and a personal view, on the speciation of *Homo sapiens*. His contribution had two clearly separated parts; the first half devoted to a review of the place of mind in the accounts of the evolution of *Homo sapiens*, the second part dealing with the relationship between brain lateralization, mental health, and language. His main point was to reveal that since the outset of evolutionary biology, the evolution of human mind has been seen as a major problem, to the point that Darwin himself left it for the future (Darwin 1859). In fact, A.R. Wallace, already in 1864, notes that even if there is no big morphological difference between men and apes, there is an enormous difference in their mental life, language being the apex of this difference. The human mind “enables him with an unchanged body still to keep in harmony with a changing universe” (Wallace, 1864: clxiii). Crow discussed the asymmetric anatomy of the brain suggesting that the hemispheric differences arise from a so-called ‘balloon model’ of cortical development (cf. Harasty *et al.* 2003). According to him, the development of the four chamber structure of the brain (maybe due to the ProtocadherinXY gene pair some 160 KYA) would be a crucial step towards the development of the capacity for language (see also Crow 2002, 2008). This brief talk provided a nice ground for the outset of the conference, given that it touched a wide range of topics that would be matter of discussion the next couple of days.

December 16<sup>th</sup> started with the discussion of the past of UG. **Wolfram Hinzen** (Durham University) set the stage with a brief presentation of three pre-Chomskyan traditions of Universal Grammar: (i) the Indian classical tradition, (ii) the medieval modistae, and (iii) the Port Royal rationalists of the 17<sup>th</sup> century. These three traditions entail three completely different visions of the nature of language and linguistics (see e.g. Covington 2009, Mukherji 2010, and Hinzen *et al.* 2011). In this introductory presentation, Hinzen compared the main themes and particular visions of each of these traditions, thus providing a nice framing for the next talk, by **Elisabeth Leiss** (University of Munich). There she explained the vision that medieval modists had of language as a technique to transform reality into mental representations, not as a means to communicate with the external world. Hence, according to the modists, the nature of these mental representations is linguistic in essence. Leiss also stressed that in this process of conceptualization, part-whole relations play a crucial role, and she explained the

modists's conception of non-nominalistic mereology, a very sophisticated theory of part-whole relations in lexical semantics and grammar which contrasts sharply with the type of set-theoretic mereology that contemporary linguists and philosophers employ. In my view, too little is known on the work of these grammarians (to the point that a large amount of manuscripts are yet to be analyzed and published), and it was very welcome to have both Hinzen's and Leiss's presentations in a conference on the nature of UG. Knowledge of the older traditions should not be relegated to conferences and textbooks on the history of linguistics, for some of the paths that we might want to construe might have been already crossed by others.<sup>1</sup>

After these talks on the 'Past of UG', the rest of the conference centered on particular visions of contemporary defendants and skeptics of UG. I would like to highlight that this is a remarkable thing; very different views were expressed (even radically opposed ones) and the debate and the exchange of ideas became rich and fluid. What follows is a sort of summary of the talks and their commentaries.

The next talk was delivered by **Ian Roberts** (University of Cambridge) and **Anders Holmberg** (Newcastle University). They presented what in my view is one of the most attractive and promising approaches to linguistic variation. The outset was to argue that the simplest idea (and one in line with common assumptions elsewhere in the cognitive sciences) was to take it as granted that there is a universal set of cognitive capacities underlying human linguistic competence. Regarding linguistic variation, they proposed a hierarchy of syntactic parameters and default values to account for the (macro- and micro-) parametric variation on word order and its emergence *qua* acquisition (language learners will posit default options in the absence of Primary Linguistic Data that would force them to go into marked options (because of 'input generalization')). Therefore, Roberts & Holmberg's proposal is that an important amount of linguistic variation takes place in narrow syntax and does not have to be restricted to externalization like, for instance, in the crosslinguistic variation observed in the patterns of answers to YES/NO questions. Roberts & Holmberg's presentation was followed by a commentary by **George Walkden** (University of Cambridge) where he clarified the notion of linguistic parameter and the factors that are involved in the shape of the acquired language. He proposed that, ideally, parameter hierarchies of the sort advocated by Holmberg & Roberts should be motivated in terms of 'natural law' (the 'fourth factor'; cf. Berwick *et al.* 2011).

Quite in contrast with these two was **Ewa Dąbrowska's** (Northumbria University) talk. Dąbrowska's presentation questioned the reality itself of UG, arguing that, among its defenders, there is no consensus on the very notion of UG, and that the arguments that have been posited in its favor are unconvincing. Among other things, she questioned the notions of species specificity, poverty of stimulus, ease of acquisition, and uniformity of the knowledge of language across the population, arguing that they are either empirically unsupported or that they can have alternative explanations. She also advocated cognitive-constructional

---

<sup>1</sup> This is also the case of rationalist grammarians like F. Sanctius Brocensis (1523–1600), precursor of Port Royal grammarians, but whose work is now largely understudied and unknown.

grammar as an alternative to minimalism (cf. Dąbrowska 2004, Goldberg 2006). As the reader might know, the type of criticism made by Dąbrowska conforms to one of the sides in a longstanding discussion in linguistics, and one that stands at the core of our scientific agenda (cf. e.g. Piattelli-Palmarini 1980, or the recent discussion in Pullum 2011 and Brenchley & Lobina 2011, after Chomsky 2011). Unfortunately, due to some technical problems with the video-conference, we were not able to listen to the comments that **Theresa Biberauer** (University of Cambridge) had prepared to Dąbrowska's presentation. At any rate, the discussion session after Dąbrowska's presentation turned out to be a very lively one.

After the discussion on the existence of UG, where each one, I believe, stayed in his/her previous position, paleontologist and systematist **Ian Tattersall** (American Museum of Natural History) provided an illuminating lecture on the speciation of *Homo sapiens* where he sketched out a general framework within which UG and language may have been acquired, particularly addressing the questions of *how* and *when* they were acquired. After an overview of the cognitive capacities and archaeological record left by each of the main branches within the genus *Homo*,<sup>2</sup> Tattersall concluded that the archaeological record strongly suggests that there is a sharp distinction between *Homo sapiens* and all the rest of the hominids in terms of mental life (as attested in tool-making, symbolic behavior, etc). What is more, even the earliest humans who looked exactly like us (from around 160,000 years ago) behaved pretty much like the cognitively less sophisticated Neanderthals. From all this he concludes that the mechanisms underwriting UG had to be acquired very recently, in an evolutionary instant, and in the context of emergence, rather than as a predictable extrapolation of pre-existing long-term hominin trends driven by natural selection. In his commentary to Tattersall's talk, **Martin Everaert** (Utrecht University) started with a piece of skepticism and stating that we should not tell stories about possible origins of language, and highlighting the need for evidence. In this regard, he argued that the meaning of the term 'symbolic', when used for 'symbolic species' and 'symbolic behavior', is not very well defined and he further questioned whether a 'symbolic' capacity is necessary for the development of language but just not enough. The discussion continued with interesting interchanges between Ian Tattersall and Noel Burton-Roberts on symbolic thoughts and Ian Tattersall and Hagit Borer on the differences in the nature and function of burials in Neanderthals and humans.

The next contribution was **Nick Chater's** (Warwick Business School), who presented the main conclusions of the work he has been developing lately with Morten Christensen, Florencia Realli, Andrea Baronchelli, and Romualdo Pastor-Satorras. The main argument of his talk was summarized in the title: "Language is shaped by the brain; but not the reverse", thus his position was that human language is built on cognitive and biological foundations that pre-date the emergence of language. Upon his view, language evolution is primarily cultural evolution; language evolves to be easy to learn and process by the language learners/speakers. As a consequence, modern languages are better shaped for communi-

---

<sup>2</sup> To the interested reader I would recommend Tattersall (2008), which provides a very approachable introduction to the evolutionary path that led to the origin of our species.

cation than ancient languages (see Chater *et al.* 2009 on the Baldwin Effect). Chater's talk was followed by a commentary by **Scott Thomas** where he clarified and extended some of the points made by Chater. As can be imagined, Chater's proposal generated a high amount of controversy during the question period.

Next came **Maggie Tallerman's** (Newcastle University) presentation, in which she put forth an adaptationist view of the evolution of human language from a pre-syntactic protolanguage. She argued that contrary to a widely accepted view in minimalism, there is no evidence in support of a recent saltational emergence of language and that, rather, syntax evolved gradually from various previous stages of protolanguage. According to her, in the evolution of language, use and externalization played a primary role, where the creation of the lexicon and syntactic rules and operations like displacement were driven by language use (i.e. for communication). This communicative goal would be, for instance, in the origin of topicalization, which would be a means of highlighting the relevant information by presenting it first in the sentence. **Joana Rosselló** (University of Barcelona) was the commentator of this talk and she argued that Tallerman's talk suffered from a number of serious flaws. Among other things, Rosselló criticized the use of the notion of externalization on the grounds that it is not a coherent concept in a functionalist approach and that externalization necessarily implies a previous internal/mental representation. Another point of her criticism was Tallerman's proposal that displacement evolved for communication. Rosselló pointed out that displacement is not necessary, or not necessarily overt (like in *wh-in situ* languages), and that it may not always be leftward (like in *wh*-questions in sign languages, cross-linguistically).

The program of the first day ended with a public lecture by **Tom Roeper** (University of Massachusetts, Amherst) where he presented in a non-technical way some of the ideas and arguments that he would develop the next day in his conference talk.

The morning session of December 17<sup>th</sup>, which was dedicated to neuroimaging studies of language and language-like cognitive capacities in humans and non-human animals, gives a nice picture of the interdisciplinarity of the conference. This session was inaugurated by **Christopher Petkov** (Newcastle University), who started with an overview of the issues and challenges inherent to the comparative study of linguistic and pattern learning. He discussed the research and experiments that he and colleagues are developing in order to assess the question of whether primates like macaques or marmosets are able to learn strings generated with different sorts of artificial grammars and if so, which brain regions support that learning. After reviewing some of their current behavioral and fMRI experiments, he argued that we can establish a link between the language-processing brain areas in humans and some homologous regions in nonhuman primates. Thus, upon his view, we can talk of a precursor system for core aspects of syntax in nonhuman primates and hence, those aspects of our syntactic capacities would not be species specific.

This presentation was followed by a critical comment by **Jeffrey Watumull** (University of Cambridge/MIT). Watumull's point was that the type of work that Petkov and colleagues are developing fails to address the difference between

'strong generativity' and 'weak generativity'.<sup>3</sup> He pointed out that this type of experiment can only assess weak generativity (the generation of certain strings) but not strong generativity (the assignment of unambiguous structural descriptions to those strings), thus, they can tell us very little as to the type of grammar that generated them. Upon his view, until the Chomsky hierarchy is revamped from weak generation to strong generation, artificial grammar experiments based on it must be adjudged dubious (see, among others, Samuels, Hauser & Boeckx to appear for discussion).

Next was **Nathalie Tzourio-Mazoyer's** (University of Bordeaux Segalen — GIN) talk. She commented on a meta-analysis based on 129 imaging articles concerning phonological, semantic and sentence-text processing tasks that provide a description of the left hemisphere phonological, semantic and syntactic regions (cf. Vigneau *et al.* 2006, 2011). She argued that their studies show that besides the strong left hemispheric dominance for language, there is also a great difference in the inter-hemispheric interactions: While left hemispheric peaks are in majority unilateral, a reversed pattern can be observed in the right hemisphere. This strongly suggests that while the left hemisphere works predominantly in an intra-hemispheric manner, the right hemisphere activity is mainly based in inter-hemispheric interactions. She also commented on the relationship between right-handedness and hemispheric specialization and, after providing an overview of the variability observable in hemispheric specialization, she questioned the existence of factors other than handedness that may be at play in setting this specialization.

The commentary to her talk was delivered by **Kai Alter** (Newcastle University). He framed Tzourio-Mazoyer's talk in a discussion of his recent work on how visual information is integrated together with auditory information during the complex task of processing emotional information like laughter (joy and taunt). He argued that this research shows the involvement of the dorsolateral prefrontal cortex (DLPFC) bilaterally, as well as the anterior rostral mediodorsal cortex (arMFC), just as in a wider range of cognitive functions such as the parsing of prosody, information evaluation, etc. These findings, then, demand for a more integrative model.

The next presentation was provided by **Gavin Clowry** (Newcastle University) who centered on human specific aspects of cerebral cortex development. He provided a detailed discussion of some of the issues that arise when using mice brains as models for human brains, arguing that cortical expansion in primates is not just quantitative, but rather, that there are some novel cortical areas which are identified by their gene expression, connectivity and functions and which are not present in rodents. One major difference is that a significant amount of human cortical neurogenesis takes place in the outer subventricular zone (an area which is significantly smaller in rodents). Related to this, he argued that the recently discovered inhibitory interneurons play a crucial role in cognitive processing, fine-tuning the oscillations in neural activity in distributed networks that underlie learning and memory. In humans, as in other primates, these interneurons are generated intracortically, but in rodents 95% of these cortical inhibitory inter-

---

<sup>3</sup> See also Brenchley & Lobina (2011) for a similar discussion in their answer to Pullum (2011).

neuros are generated outside the cortex, at the ganglionic eminences, and they migrate to the cortex during development. Another main difference that he discussed is brain asymmetry and lateralization, which play a crucial role in human brain development. This talk was followed by an illuminating commentary by **Tim Crow** (Oxford University) where he brought into discussion his own research on the nature of the brain torque (a bias across the antero-posterior axis whereby the dorsolateral prefrontal cortex on the right hemisphere is thinner and wider than that on the left side, and the occipito-parieto-temporal cortex is thinner and wider on the left than the right). He argued that the human brain has four quadrants of association cortex left and right motor, and right and left sensory which distinguishes it from that of all other mammals. In this regard, he vindicated the relevance of the study of schizophrenia for the research on the evolution of lateralization and language, given that in this pathology we can observe instances where the deictic frame (i.e. the distinction between compartments) breaks down (see e.g. Crow 2010 for discussion).

The presentation by **Wolfram Hinzen** (Durham University) provided an innovative analysis of what UG is and of the nature of language itself. He argued against one of the core assumptions of the computational theory of mind; the idea of the availability of a grammar-independent Language of Thought that builds representations upon computations on symbolic objects (see Fodor 1975, 2008, Fodor & Pylyshyn 1988). After discussing some evidence against the postulation of a propositional Language of Thought in nonlinguistic animals (see also Terrace 2005, Penn *et al.* 2008), Hinzen went on to explore the idea that there is a causal connection between language and a human-specific format of thought which is referential and propositional, and which appears to be very recent in evolutionary terms. He framed his discussion within the research that he has been developing over the last years on the nature of semantics and the function of Merge and the phase-structure of syntax: non-recursive predication relations arise biphasally, generating formal-ontological distinctions such as 'object', 'event', and 'proposition' (see also Sheehan & Hinzen (2011) for a detailed exposition of this idea). In a nutshell, with the system depicted by Hinzen, the basic ontology of thought and semantics emerge as grammatical complexity increases, and no other Language of Thought theory is needed. The locus of human thought is placed in grammar and hence we can deny the necessity of postulating an 'interface' between language and a language-independent thought (the 'Conceptual-Intentional' systems of Chomsky 1995, for example). As a corollary, UG is not subject to parametric variation. **Noel Burton-Roberts** (Newcastle University) commented on some of Hinzen's points and centered on the relationship between language and thought. He compared Hinzen's position with that of B.L. Whorf, to which an interesting debate ensued.

**Tom Roeper** (University of Massachusetts, Amherst) opened the language acquisition session of the afternoon. His exposition started with a programmatic note; he argued that a critical goal of future work in UG must be to clarify: (i) how current generalizations reflect interface relations and (ii) how a theory of interfaces can constrain the language acquisition process. He then discussed some of the general biases that children employ when acquiring their native language. In particular, he argued for a theory of 'strict interfaces'. This theory



makes the formal claim that there is no linguistic variation in how modules connect, and the substantive claim that there are substantive ‘strict interfaces’ which are universal. He further proposed that a bias that children use is that of ‘Minimal Modular Contact’; the idea that there is a single connection point between modules (a feature he linked with economy of design). The effects of this Minimal Modular Contact, he argued, can be observed in a variety of phenomena like the adoption of a ‘general point of view’, the generalization to one single operator, negative concord, the sequence of tense phenomena, etc. In my commentary to Roeper’s talk, I framed his proposal within the generally accepted inverted Y-model of the architecture of grammar and underlined the predictions that this model makes regarding the class of possible languages. I also proposed some extensions of his ideas by exploring the possibility of applying them to other areas like the pair-list readings of multiple *wh*-questions, or the cross-linguistic unavailability of truly verbal *wh*-words.

Next came **Rosemary Varley**’s talk (University of Sheffield). She analyzed the relationship between language and thought by exploring the cognitive capacities of patients with language-related pathologies like global aphasia or agrammatic aphasia (see, among many others, Bek *et al.* 2010). After reviewing a number of studies and experiments, she concluded that there is no evidence of co-variation between language and reasoning in severely aphasic people; in fact, as some experiments suggest, our reasoning ability can be retained in the face of profound impairment of grammar. Furthermore, she stressed that aphasia should not be automatically seen as a matter of performance, but as a matter of competence. Thus, her conclusion is that the evidence from aphasic patients reveals that grammar is not necessary to support reasoning, and that there is considerable autonomy between language and thought. **Alex Drummond** (Durham University) extended and commented some of Varley’s major points.

The last presentation of the conference came from **Jill de Villiers** (Smith College). She built her presentation upon some recent experimental work with adults that addresses the question: does combinatorial Merge of lexical concepts depend on access to the language faculty? She discussed studies analyzing whether children and adults can have the representations of complex eventualities with agents and themes but without language. In particular, the studies showed that (i) adults could not *remember an event* while their language faculty is tied up, such that they can recognize a new instance of that event, i.e. one describable by the same sentence, (ii) children could not ‘hold’ the 3-term event (SVO, agent – event – theme) to generalize it if they did not have the experience of a verbal description of it, and (iii) that tying up the linguistic capacity of adults with a different task made impossible the recognition of the similarity across a class of events sharing a proposition. A fourth experiment suggested that “natural kind” concepts and negation are about equally abstract for adults without experimental shadowing, but dramatically different under conditions of shadowing. She also discussed the implications of these findings for the relationship between language and thought, opening a new set of research questions to explore in the future. De Villiers’ presentation was commented by **Annie Gagliardi** (University of Maryland) and that brought the Conference on UG to an end.

The session of December 18<sup>th</sup> was devoted to a ‘satellite workshop’ on minimalist theorizing and counted with presentations by **Hagit Borer** (University of Southern California), who discussed the so-called Borer–Chomsky conjecture and the combinatorial operations that generate words and **Halldór K. Sigurðsson** (Lund University), who argued for a novel theory of externalization with a non-isomorphic mapping from I-Language to E-Language. Besides, in my view, it was very fortunate that the last two talks of the meeting were representative of two very different, but complementary, argumentation styles in minimalist linguistic theorizing: A talk on phrase structure and cyclic transfer by **T. Daniel Seely** (Eastern Michigan University), which was a neat and clear exponent of the deductive style and reasoning that he and his colleagues have been employing over the last years, and the counterpart in style to this talk, which was the talk by **Michelle Sheehan** (University of Cambridge), who presented a powerful and comprehensive inductive analysis of the crosslinguistic variation in the PF component, especially regarding the availability of *pro*-drop.

## References

- Ayoun, Dalila. 2003. *Parameter Setting in Language Acquisition*. London: Continuum.
- Baker, Mark C. 2005. The innate endowment for language: Underspecified or overspecified? In Peter Carruthers, Stephen Laurence & Stephen Stich (eds.), *The Innate Mind: Structure and Concepts*, 156–174. Oxford: Oxford University Press.
- Baker, Mark C. 1996. *The Polysynthesis Parameter*. New York: Oxford University Press.
- Bek, Judith, Mark Blades, Michael Siegal & Rosemary Varley. 2010. Language and spatial reorientation: Evidence from severe aphasia. *Journal of Experimental Psychology: Learning, Memory, and Cognition* 36, 646–658.
- Berwick, Robert, Paul M. Pietroski, Berach Yankama & Noam Chomsky. 2011. Poverty of Stimulus revisited. *Cognitive Science* 35, 1207–1242.
- Boden, Margaret A. 2006. *Mind as Machine: A History of Cognitive Science*. New York: Oxford University Press.
- Boden, Margaret A. 2007. Odd man out: A reply to reviewers. *Artificial Intelligence* 172, 1944–1964.
- Boeckx, Cedric. 2011. Approaching parameters from below. In Anna Maria di Sciullo & Cedric Boeckx (eds.), *The Biolinguistic Enterprise: New Perspectives on the Evolution and Nature of the Human Language Faculty*, 205–221. Oxford: Oxford University Press.
- Borer, Hagit. 1984. *Parametric Syntax: Case Studies in Semitic and Romance Languages*. Dordrecht: Foris.
- Brenchley, Marc & David J. Lobina. 2011. Re: Remarks by Noam Chomsky in London. *Linguist List* 22, 4650. [<http://linguistlist.org/issues/22/22-4650.html>]
- Chater, Nick, Florencia Reali & Morten Christiansen. 2009. Restrictions on biological adaptation in language evolution. *Proceedings of the National Academy*

- of Sciences*, 106, 1015–1020.
- Chomsky, Noam. 2011. On the poverty of stimulus. Talk delivered at University College London, 10 October 2011.
- Chomsky, Noam. 2007. Symposium on Margaret Boden, *Mind as Machine: A History of Cognitive Science*, Oxford, 2006, two volumes. *Artificial Intelligence* 171, 1094–1103.
- Chomsky, Noam. 1965. *Aspects of the Theory of Syntax*. Cambridge, MA: MIT Press.
- Chomsky, Noam. 1966. *Cartesian Linguistics: A Chapter in the History of Rationalist Thought*. New York: Harper & Row.
- Chomsky, Noam. 1995. *The Minimalist Program*. Cambridge, MA: MIT Press.
- Clark, Alexander & Shalom Lappin. 2011. *Linguistic Nativism and the Poverty of the Stimulus*. Oxford & Malden, MA: Wiley-Blackwell.
- Covington, Michael A. 2009. *Syntactic Theory in the High Middle Ages*. Cambridge: Cambridge University Press.
- Crain, Stephen & Paul Pietroski. 2001. Nature, nurture and Universal Grammar. *Linguistics and Philosophy* 24, 139–186.
- Crow, Timothy J. 2010. The nuclear symptoms of schizophrenia reveal the four quadrant structure of language and its deictic frame. *Journal of Neuro-linguistics* 23, 1–9.
- Crow, Timothy J. 2008. The ‘big bang’ theory of the origin of psychosis and the faculty of language. *Schizophrenia Research* 102, 31–52.
- Crow, Timothy J. 2002. Sexual selection, timing and an X-Y homologous gene: Did *Homo sapiens* speciate on the Y chromosome? In J. Crow (ed.), *The Speciation of Modern Homo Sapiens*, 197–216. New York: Oxford University Press.
- Dabrowska, Ewa. 2004. *Language, Mind and Brain: Some Psychological and Neurological Constraints on Theories of Grammar*. Edinburgh: Edinburgh University Press.
- Eco, Umberto. 1993. *Ricerca della Lingua Perfetta nella Cultura Europea*. Rome and Bari: Laterza [transl. *The Search for the Perfect Language*. Oxford: Blackwell, 1995.]
- Elman, Jeffrey L., Elizabeth A. Bates, Mark H. Johnson, Annette Karmiloff-Smith, Domenico Parisi & Kim Plunkett. 1996. *Rethinking Innateness: A Connectionist Perspective on Development*. Cambridge, MA: MIT Press.
- Fodor, Jerry A. 2008. *LOT 2: The Language of Thought Revisited*. New York: Oxford University Press.
- Fodor, Jerry A. 1975. *The Language of Thought*. Cambridge, MA: Harvard University Press.
- Fodor, Jerry A. & Zenon Pylyshyn. 1988. Connectionism and cognitive architecture: A critical analysis. *Cognition* 28, 3–71.
- Goldberg, Adele E. 2006. *Constructions at Work: The Nature of Generalization in Language*. Oxford: Oxford University Press.
- Hale, Mark & Charles Reiss. 2003. The Subset Principle in phonology: Why the *Tabula* can’t be *rasa*. *Journal of Linguistics* 39, 219–244.
- Hauser, Marc D., Noam Chomsky & W. Tecumseh Fitch. 2002. The faculty of language: What is it, who has it, and how did it evolve? *Science* 298, 1569–1579.

- Harasty, Jenny, *et al.* 2003. The left human speech-processing cortex is thinner but longer than the right. *Laterality* 8, 247–260.
- Hinzen, Wolfram. 2006. *Mind Design and Minimal Syntax*. Oxford: Oxford University Press.
- Hinzen, Wolfram, Nirmalansu Mukherji & Bijoy Boruah. 2011. The character of mind. *Biolinguistics* 5, 274–283.
- Hornstein, Norbert & David Lightfoot (eds.). 1981. *Explanation in Linguistics: The Logical Problem of Language Acquisition*. London & New York: Longman.
- Lightfoot, David. 1993. *How to Set Parameters: Arguments from Language Change*. Cambridge, MA: MIT Press.
- Mukherji, Nirmalanshu. 2010. *The Primacy of Grammar*. Cambridge, MA: MIT Press.
- Musso, Mariacristina, Andrea Moro, Volkmar Glauche, Michel Rijntjes, Jürgen Reichenbach, Christian Büchel & Cornelius Weiller. 2003. Broca's area and the language instinct. *Nature Neuroscience* 6, 774–781.
- Niyogi, Partha. 1996. *The Computational Nature of Language Learning and Evolution*. Cambridge, MA: MIT Press.
- Penn, Derek C., Keith J. Holyoak & Daniel J. Povinelli. 2008. Darwin's mistake: Explaining the discontinuity between human and nonhuman minds. *Behavioral and Brain Sciences* 31, 109–178.
- Piattelli-Palmarini, Massimo (ed.). 1980. *Language and Learning: The Debate between Jean Piaget and Noam Chomsky*. Cambridge, MA: Harvard University Press.
- Premack, David. 1980. Representational capacity and accessibility of knowledge: The case of chimpanzees. In Massimo Piattelli-Palmarini (ed.), 1980, 203–221.
- Pullum, Geoff. 2011. Remarks by Noam Chomsky in London. *Linguist List* 22, 4631. [<http://linguistlist.org/issues/22/22-4631.html>]
- Roberts, Ian. 2007. *Diachronic Syntax*. Oxford: Oxford University Press.
- Samuels, Bridget, Marc Hauser & Cedric Boeckx. To appear. Do animals have universal grammar? Phonology as a case study. In Ian Roberts (ed.), *The Oxford Handbook of Universal Grammar*. Oxford: Oxford University Press.
- Sheehan, Michelle & Wolfram Hinzen. 2011. Moving towards the edge. *Linguistic Analysis* 37, 405–458.
- Smith, Neil & Ianthi Maria Tsimpli. 1995. *The Mind of a Savant: Language Learning and Modularity*. Oxford: Blackwell.
- Tattersall, Ian. 2008. *The World from Beginnings to 4000 BCE*. New York: Oxford University Press.
- Terrace, Herman S. 2005. Metacognition and the evolution of language. In H. S. Terrace & J. Metcalfe (eds.), *The Missing Link in Cognition*, 84–115. New York: Oxford University Press.
- Vigneau, Mathieu *et al.* 2011. What is right-hemisphere contribution to phonological, lexico-semantic, and sentence processing? Insights from meta-analysis. *NeuroImage* 54, 577–593.
- Vigneau, Mathieu *et al.* 2006. Meta-analyzing left hemisphere language areas: Phonology, semantics, and sentence processing. *NeuroImage* 30, 1414–1432.
- Wallace, Alfred R. 1864. The origin of human races and the antiquity of man deduced from the theory of 'natural selection'. *Journal of the Anthropological*

*Society of London 2*, clviii–clxxxvii.

Wallman, Joel. 1992. *Aping Language*. Cambridge: Cambridge University Press.

Yang, Charles. 2003. *Knowledge and Learning in Natural Language*. New York: Oxford University Press.

*Aritz Irurtzun*  
CNRS-Iker (UMR 5478)  
Château Neuf  
15 Place Paul Bert  
Bayonne 64100  
The Basque Country  
France  
[aritz.irurtzun@iker.cnrs.fr](mailto:aritz.irurtzun@iker.cnrs.fr)

# *Biolinguistics*

Volume 6, Issue 1

Winter 2012

## TABLE OF CONTENTS

- 001 Solving the UG Problem  
Denis Bouchard  
*Université du Québec à Montréal*
- 032 English-Speaking Children's Interpretation  
of Disjunction in the Scope of 'not every'  
Anna Notley  
Rosalind Thornton  
Stephen Crain  
*Macquarie University*
- ★ BRIEFS ★
- 070 All Tied in Knots  
David J. Lobina  
*Universitat Rovira i Virgili*
- ★ FORUM ★
- 079 Knots, Language, and Computation: A Bizarre  
Love Triangle? Replies to Objections  
Sergio Balari  
*Universitat Autònoma de Barcelona  
& Centre de Lingüística Teòrica*  
Antonio Bénitez-Burraco  
*Universidad de Huelva*  
Marta Camps  
*George Washington University*  
V́ctor M. Longa  
*Universidade de Santiago de Compostela*  
Guillermo Lorenzo  
*Universidad de Oviedo*
- 112 The Present of UG  
Aritz Irurtzun  
*CNRS-Iker (UMR 5478)*

